

Electrode Steam Humidifier

MiniSteam



A Word about Water Quality

The mode of operation of all electrode steam humidifiers is based on the fact that water contains minerals and is therefore conductive.

- "normal" tap water is ideal.
- but what is "normal" tap water exactly?

Users of HygroMatik units in the most diverse areas consider their tap water "normal."

HygroMatik typically defines "normal" as feed water with a conductivity between 200 and 500 $\mu\text{S/cm}$ (microSiemens per centimeter) at 15° C.

Some areas, however, are supplied with tap water whose quality is outside the parameters specified by HygroMatik. If the HygroMatik steam humidifier's control is not adjusted correctly in these areas, the unit cannot perform optimally. For example, the electrodes could wear out particularly quickly or the steam production could be too low.

The operational parameters set by HygroMatik in the factory are intended for normal tap water. However, they can very easily be reprogrammed to fit the special requirements of a particular area. In addition, it is possible to install a plastic star in the cylinder in order to increase the life span of the electrodes or to provide a flushing mechanism to extend maintenance intervals.

Because of this you should monitor your new unit during initial operation. Make sure that it has been properly installed and is operating to your satisfaction.

Consult your HygroMatik specialists. We will test the quality of your water and advise you on installation and initial operation. Your HygroMatik steam humidifier will be carefully adapted to your particular application.

© Copyright HygroMatik GmbH; MiniSteam, 21.10.2015

Information in this manual is subject to change or alteration without prior notice.

Current version of this manual can be found at: www.airtrend.rs



Warning, Hazardous Voltage: All work to be performed by trained personnel only. All electrical installation and servicing of the electrical components of this unit to be performed by qualified electricians only. Disconnect power supply before installation and servicing!

1. Introduction	5
1.1 Directions for Use	5
1.2 Typographic Distinctions	6
1.3 Documentation	6
2. Safety Notes	7
2.1 Overview	7
2.2 Guidelines for Safe Operation	7
2.3 Disposal after Dismantling	8
3. Transport	9
3.1 Overview	9
3.2 Carton outer Size and Weight	9
3.3 Packing	10
3.4 Interim Storage	10
3.5 Check for Complete and Correct Delivery of Goods	10
3.6 Included in the Delivery	10
4. Operation and Installation	11
4.1 Mode of Operation	11
4.2 Installation and Operation	11
5. Installation	15
5.1 Steam Humidifier Operating Environment	15
5.1.1 Fitting measures	16
5.2 Unit Installation Check	17
5.3 Unit Dimensions	18
6. Water Installation	19
6.1 Operation with Softened Water	19
6.2 Water Supply	20
6.3 Water discharge	21
6.4 Water Installation Check	22
7. Electrical Connection	23
7.1 Electrical Installation	23
7.2 Cable Connections	25
7.3 Safety Interlock	26
7.4 Wiring Diagram	26
7.5 Electrical Installation Checklist	26
8. Maintenance	27
8.1 Maintenance Work	28
8.2 Access Electrical Enclosure	29
8.3 Removing and Cleaning the Steam Cylinder	30
8.4 Electrode wear	33
8.4.1 Original Electrode Lengths	33
8.4.2 Uneven Electrode Lengths	34
8.5 Replacing Electrodes	34
8.6 Cleaning the Blow- Down Pump	36

8.7 Cleaning the Water Inlet Solenoid Valve 36

8.8 Chekking Cable Connections and Electrode Cables 37

8.9 Checking Operation 37

8.10 Dismantling 37

9. Commissioning 38

10. EC-Declaration of Conformity 39

11. Spare Parts 40

12. Fax Form - Order for spare parts 42

13. Technical Data 43

14. Exploded View 44

15. View of housing 45

1. Introduction

Dear Customer,

Thank you for choosing a HygroMatik steam humidifier.

HygroMatik steam humidifiers represent the latest in humidification technology.

They will impress you with their safety, ease of use and economical operation.

In order to operate your HygroMatik steam humidifier safely, properly and efficiently, please read these operating instructions.

Employ your steam humidifier only in sound condition and as directed. Consider potential hazards and safety issues and follow all the recommendations in these instructions.

If you have additional questions, please contact us:

AIRTREND Limited

Predstavništvo u Beogradu

Kumanovska 14, 11000 Beograd

Tel: 011 383 68 86, 308 57 40

Faks: 011 344 41 13

e-mail: gobrid@eunet.rs

web: www.airtrend.rs

For all technical questions or spare parts orders, please be prepared to provide unit type and serial number (see name plate on the unit).

1.1 Directions for Use

The HygroMatik steam humidifier is intended for steam production.

Proper usage also entails following HygroMatik's instructions for installation, dismantling, reassembly, initial operation and operation and maintenance, as well as disposal procedures.

Only qualified, authorized personnel may operate or service the unit. Workers who transport or service the unit must have read and understood the relevant sections of the operating instructions, especially the section "Safety Notes." In addition, staff must receive safety training about potential hazards from the operator. Place a copy of the operating instructions at the location where the unit is operated.

Use feed water with a conductivity between 125 and 1250 $\mu\text{S}/\text{cm}$ only

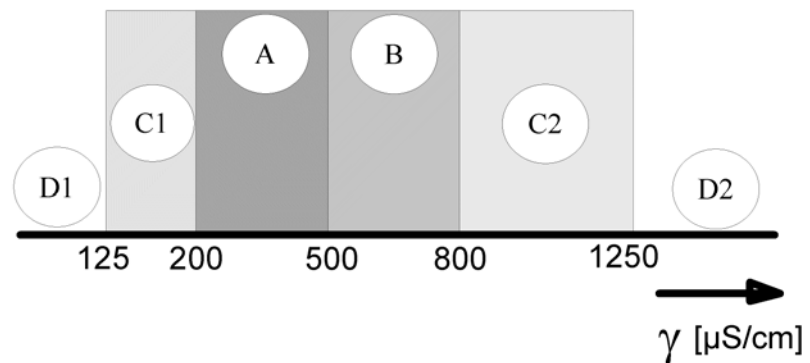

- D1: Lower threshold
- C1: Range of reduced conductivity
- A: Normal tap water
- B: Range of heightened conductivity
- C2: Range of high conductivity
- D2: Upper threshold



Warning: HygroMatik steam humidifiers emit steam with a temperature of 100° C. The steam may not be inhaled directly.

The HygroMatik Steam Humidifier is not designed for outdoor fitting.

1.2 Typographic Distinctions

- preceded by a bullet: general specifications.
- » preceded by an arrow: Procedures for servicing or maintenance which should or must be performed in the indicated order.
- Installation step which must be checked off.
- italics* Terms used with graphics or drawings.

1.3 Documentation

Retention

Please retain these operating instructions in a secure, always accessible location. If the product is resold, turn the documentation over to the new operator. If the documentation is lost, please contact HygroMatik.

Versions in Other Languages

These operating instructions are available in several languages. If interested, please contact HygroMatik or your HygroMatik dealer.

2. Safety Notes

2.1 Overview

These safety notes are required by law. They promote workplace safety and accident prevention.

Warnings and Safety Symbols

The safety symbols below identify sections containing warnings about hazards or potential dangers. Please familiarize yourself with these symbols.



Warning: Failure to observe this warning may result in serious injury or death and/or damage to the unit.



Danger, Hazardous Voltage: Hazardous electrical current! Failure to observe this warning may result in injury or even serious injury or death.



Warning: Failure to follow these instructions may result in damage to the unit due to electrostatic discharge. The electronic components of the humidifier control are very sensitive to electrostatic discharges. In order to safeguard these components during installation and servicing, steps must be taken to protect against ESD.



Reminder: Materials and consumables must be handled and/or disposed of as required by law.



Note: Appears before explanations or cross-references which refer to other sections of the operating instructions.



Caution
steam

2.2 Guidelines for Safe Operation

Overview

Obey all safety notes and warnings present on the unit.

In case of a malfunction, switch off the unit immediately and prevent a restart. Repair malfunctions promptly. After any repair work, have qualified personnel check the safe operation of the unit.

Use original spare parts only. Additional national safety regulations also fully apply to the operation of this unit.

This unit is not designed for the use by persons (also children) with limited physical, sensory and mental abilities - or without knowledge and experience. Unless they are supervised or trained by a person, who is responsible for their safety.

Supervise children in order to ensure that they will not play with the unit.

The unit is only allowed to work with connected steam hose that safely leads the steam.

Accident Prevention Regulations



Attention: In the event of leaky or faulty components uncontrolled hot steam may flow.

HygroMatik steam humidifiers are IP20-protected. Make sure that the unit is protected from drips in its installed location.

Installing a humidifier in a room without water discharge requires safety devices to protect against water leakages.

Accident Prevention Regulations



Comply with the Accident Prevention Regulation Electrical Systems and Equipment to prevent injury to yourself and others.

Operation of the Unit:

Do not perform any work which compromises the safety of the unit. Regularly check that all safety and monitoring devices are functioning normally. Do not remove or disable safety devices.

Installation, Dismantling, Maintenance and Repair of the Unit:

Disconnect unit components from power supply prior to maintenance or repair work.

Attaching or installing **additional components** is permitted only with the **written consent** of the manufacturer.

Electrical



Work on the electrical system must be performed by qualified personnel.

Disconnect unit components from power supply prior to work.

It is not allowed to connect the unit to DC voltage supply.

In case of a malfunction in the electrical power supply, switch off the unit immediately. Use only original fuses with the appropriate amperage rating. Regularly check the unit's electrical equipment. Promptly repair any damage, such as loose connections, burned wiring or defective electrical insulation. After proper electrical installation or repair, test all safety mechanisms (such as grounding resistance).

2.3 Disposal after Dismantling



Note: The operator is responsible for the disposal of unit components as required by law.

3. Transport

3.1 Overview



Note: Proceed carefully when transporting the steam humidifier in order to prevent damage due to stress or careless loading and unloading.

3.2 Carton outer Size and Weight

HyLine:

Type*	Height [cm]	Width [cm]	Depth [cm]	Weight [kg]
HY05- 08	58	56	32	16
HY13- 17	75	63	37	24
HY23	75	63	37	25
HY30	81	67	41	33
HY45	88	76	48	46
HY60	80	104	41	54
HY90- 116	90	117	48	77

CompactLine:

Type*	Height [cm]	Width [cm]	Depth [cm]	Weight [kg]
C01	46	45	26	11
C02	48	44	31	12
C06	52	50	28	13
C10	58	51	31	14
C17	75	54	37	22
C22	75	54	37	22
C30	75	58	37	23
C45	81	63	41	25
C58	90	72	48	36

MiniSteam:

Type*	Height [cm]	Width [cm]	Depth [cm]	Weight[kg]
MS 5	59	48	28	13
MS 10	68	51	31	15

* Dimensions and weights may vary slightly.

3.3 Packing



Note: Notice the symbols affixed to the packing box.

3.4 Interim Storage

Store the unit in a dry place and protect from frost.

3.5 Check for Complete and Correct Delivery of Goods

Upon receipt of the unit, confirm that:

- the type and serial number on the name plate match those specified in the order and delivery documents and
- the equipment is complete and all parts are in perfect condition



Note: In case of damage during shipment or missing parts, immediately notify the carrier or supplier in writing.

Time limits for filing freight claims with shipping companies are*:

Shipping Companies	After Receipt of Goods
Mail	no later than 24 hours
Rail	no later than 7 days
Truck and Rail Carriers	no later than 4 days
Parcel Service	immediately

* Time limits for some services subject to change.

3.6 Included in the Delivery

The delivery includes:

- Unit of the selected humidifier type including selected control.
- Water installation hose 0,6m, 3/4".
- Mounting set with anchors and screws. For HyLine types HY45 to HY116, extra mounting bar.
- Operating Instructions for the unit and the control.
- Ordered accessories (steam manifold, steam hose, condensate hose, etc.).
- Maintenance o-ring set for steam cylinder.

4. Operation and Installation

4.1 Mode of Operation

The HygroMatik steam humidifier utilizes the conductivity normally present in tap water for steam production. Electrodes inside an enclosed steam cylinder are immersed directly into the tap water. They are connected to the alternating current.

The conductivity of the water generates an electric current between the electrodes. In this way, the electric power supplied is converted directly into heat without energy loss.

The amperage is a function of the available voltage, the immersed electrode surface area, the average distance between the electrodes and the water conductivity. The steam output of the humidifier is determined by electric power usage, which is regulated by increasing or decreasing the immersed surface area of the electrodes.

Concurrently, a self-regulating control keeps conductivity within a specified range.

The steam produced has a temperature of about 100°C with minimal excess pressure ("pressureless steam"). It is largely free of minerals and germ-free. Mineral deposits typically remain behind in the cylinder.

4.2 Installation and Operation

When the controller specifies an increase in humidity, the main contactor is switched on and the electrodes (48) are supplied with power. The water inlet solenoid valve (25) feeds water into the steam cylinder (16+19).

As soon as the electrodes are immersed, the current begins to flow. The water is now heated. When the pre-selected output is reached, the control turns off the solenoid valve and interrupts the water supply.

After a short heating up period, the water between the electrodes begins to boil and vaporize. The vaporization lowers the water level (W) in the steam cylinder, reducing the output provided. The inlet solenoid valve, equipped with a fine mesh filter, intermittently admits fresh water.

Humidifier power usage is continuously monitored. With a cold start-up, the nominal current increases to 125% in order to achieve quick-start output parameters. This activates the electronic overflow limiter which causes a partial draining of the cylinder. This reduces the immersed surface area of the electrodes, lowering power usage.

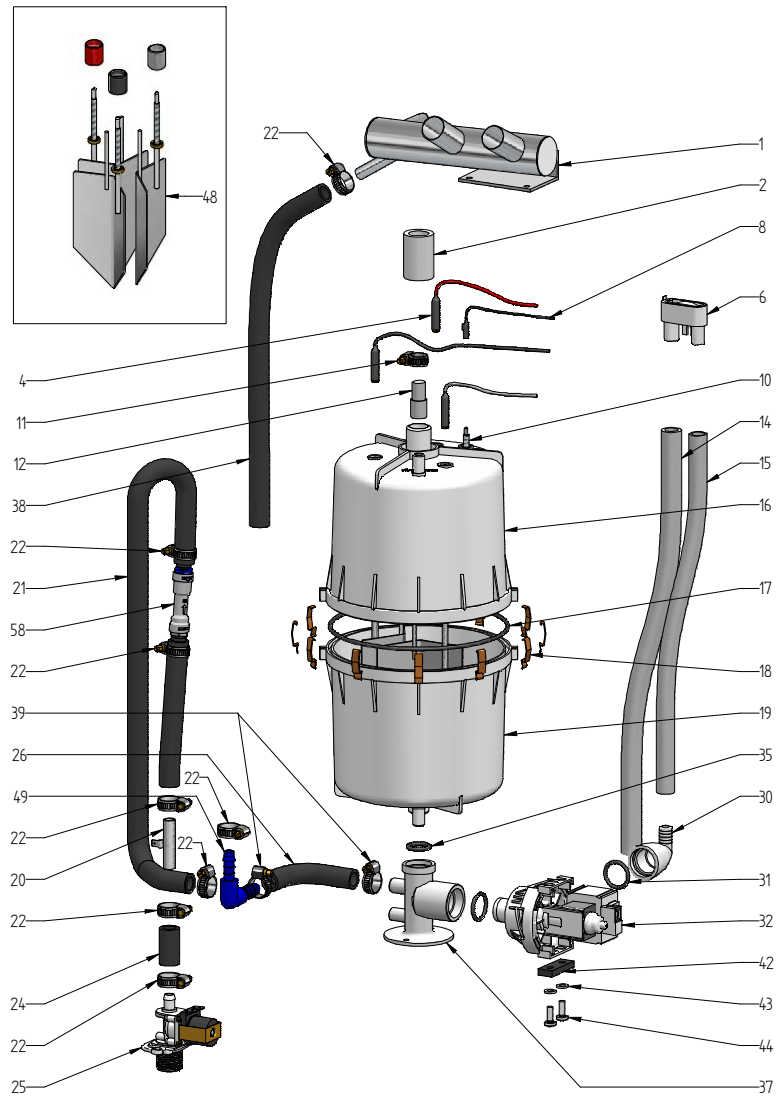

Please also see Section „Exploded View“.

Location	Designation
1	steam nozzle
6	vent pipe
10	max. water level sensor electrode
14	water drain, discharge
16	top part of steam cylinder
17	o-ring cylinder flange
18	cylinder flange and o-ring
19	lower part of cylinder
25	solenoid valve water inlet
32	blow-down pump
35	o-ring
37	cylinder base
48	electrodes

The concentration of dissolved salts increases over time, which can lead to a rise in the conductivity of the water. If this continues, conductivity may increase until a short circuit occurs. This could damage the unit, but in any case would significantly reduce the life span of the electrodes.

For this reason, regular, periodic blow-downs of some of the concentrated water are very important. Following this procedure as recommended provides stable cylinder water conductivity as well as minimal water loss for the expected service life of the cylinder.

Water blow-down is performed by a blow-down pump (32). The functioning of the blow-down pump is continuously monitored during operation. If the pump is damaged, the steam humidifier shuts down.

With normal water quality, the blow-down loss rate is between 7% and 15% of the amount of steam produced. The steam cylinder requires complete drainage every 3-8 days, regardless of the water quality.

Mineral deposits settle in the open area below the electrodes and are removed through periodic maintenance. The blow-down pump itself has wide openings and can flush out smaller pieces of mineral deposit. This extends the service life of the unit and reduces the required maintenance interval.

During blow-downs, water flows from the pump into the drainage system.

A sensor electrode (10) monitors the maximum water capacity of the cylinder. When the water level reaches the sensor electrode, the water supply is interrupted. This can occur when the water has low conductivity or when the electrodes are worn out. In the case of low water conductivity, however, this state usually lasts only a short time. The built-in control and the large area electrodes combine to produce a rapid rise in conductivity by increasing the concentration of the water.

The steam cylinder consists of a top (16) and lower (19) part joined with a cylinder flange. The seal between the cylinder and cylinder base (37), as well as between the top and lower part of the cylinder, is maintained by o-rings (17, 35).



Warning:

- During operation and also soon afterwards the steam nozzle is hot! If touched this can cause burns to the skin.
- During operation the cross-flow fan rotates. Do not touch the fan during operation.
- During operation hot steam discharges from the nozzle. In the field of the visible steam cloud contact can cause burns to the skin.
- Due to pollution or incorrect installation hot water could discharge from the nozzle.

5. Installation



Warning: Installation of this unit to be attempted only by qualified personnel. We accept no liability for damage due to faulty installation.

Obey all safety notes and warnings present on the unit.

During installation the unit must be disconnected from its power supply.

Attaching or installing additional components is permitted only with the written consent of the manufacturer, or else the warranty is void.

5.1 Steam Humidifier Operating Environment



Note: When selecting the installation site for the steam humidifier, note that:

- Ambient temperature must be between 5° and 40° C.
- Relative humidity must not exceed 80% RH.
- The minimum clearances indicated in the diagram below must be observed; these are necessary to ensure adequate ventilation for the housing.
- The rear panel of the steam humidifier heats up during operation (to a maximum of 60°C). Take care that the construction on which the unit is mounted is not made of temperature-sensitive material.
- Place the steam humidifier so that the unit is easily accessible with sufficient space to perform maintenance.
- Make sure that there are no people and bearing materials below the steam cloud (approx. 3 meters in exhaust direction).
- The steam humidifier is not qualified for exterior applications.

5.1.1 Fitting measures

Wall Distances [mm]

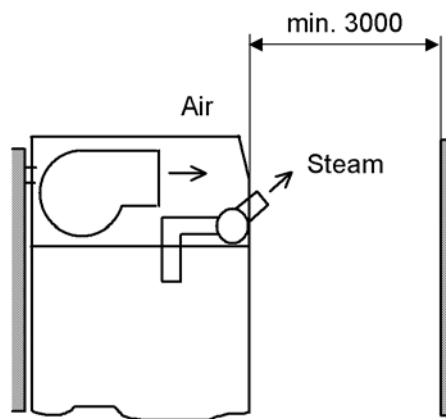
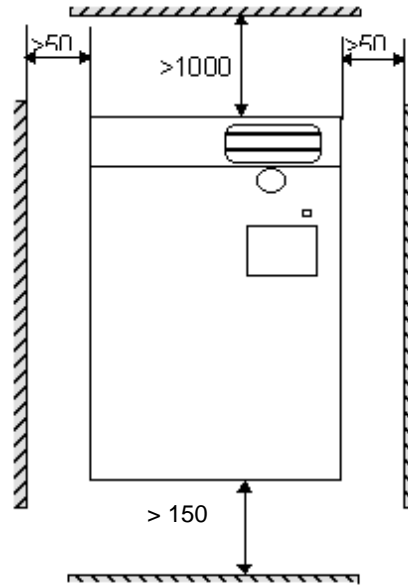

Wall Mounting

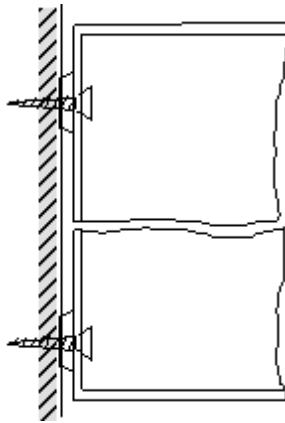

Note: The steam humidifier must be installed vertically in order to function properly.



Note: The steam humidifier should be positioned such that draught effects are avoided. The minimum height is 0.15 m above floor level but we propose a height of 2m in order to avoid scalding.



Warning: If the installation of this unit is attempted by only one person there is a risk that the unit drops down. We propose to carry out the installation by two persons.

- » Position the steam humidifier in the planned location, adjust with spirit level and mark position of hanging bolts. See also "Equipment Dimensions".
- » Hang the unit onto bolts screwed into the marked position.

5.2 Unit Installation Check



Attention: This unit may only be operated by qualified and properly trained personnel.

Please check the installation using the following list:

- Does unit hang vertically?
- Are wall distances to the unit within the range
- Is the unit installed in such a way that draught effects are avoided?
- Are all bolts and clamps tightened?

5.3 Unit Dimensions

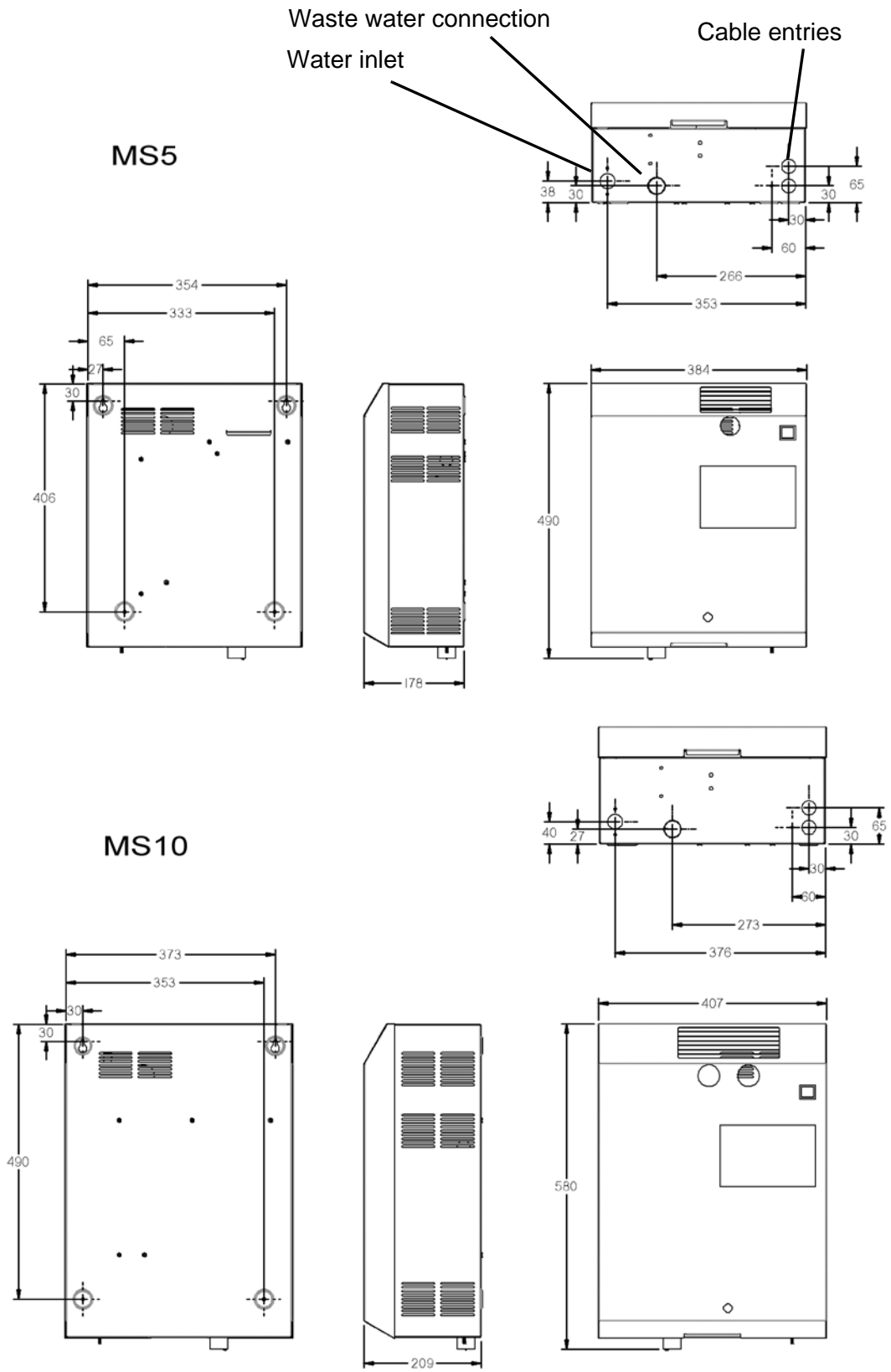

6. Water Installation



Warning: When installing the water installation, note the following:

- Have all work performed by a professional.
- Disconnect power supply before installation.
- Obey local public utility regulations
- Verify that necessary safety measures have been taken – in compliance with either German Technical and Scientific Association for Gas and Water (DVGW) guidelines (DIN EN1717) or local regulations – to eliminate backflow of polluted water into drinking water treatment facilities. This can mean installing a backflow preventer and a free discharge into the drainage system. Within the humidifier, a double check valve (58) is located in the water supply line. It prevents - in accordance with DIN EN 61770 - the backflow of water. Alternatively, a DVGW-conform HyFlow may be used that makes further safety measures obsolete.
- Use feed water without chemical additives and with a conductivity between 200 and 800 $\mu\text{S}/\text{cm}$ only. Above conductivity levels of 800 $\mu\text{S}/\text{cm}$ to a maximum of 1250 $\mu\text{S}/\text{cm}$ and below conductivity levels of 200 $\mu\text{S}/\text{cm}$ to a minimum of 125 $\mu\text{S}/\text{cm}$, special adjustments are required. In this case please contact HygroMatik.
- The water supply temperature may not exceed 40° C.
- Water installation pressure: 1 - 10 bar (100 x 10³ to 100 x 10⁴ pascal).
- Blow-down water must be able to drain.
- For water installation please use the water connecting hose that is delivered with the unit.

6.1 Operation with Softened Water



Warning: Unless special measures are taken, feeding softened water into the HygroMatik steam humidifier is dangerous. It can cause

- unacceptably high conductivity
- the formation of salt bridges between the electrodes and the electrode leads on the inner surface of the top part of the steam cylinder
- foaming in the steam cylinder

Salt bridges cause electrical arcs. These are indicated by the presence of black grooves in the top part of the cylinder. The top part must be replaced to prevent further damage to the cylinder material, as well as short circuits which trip main circuit breakers.



Foam comes into contact with the maximum water level sensor electrode and triggers a signal indicating the cylinder is filled to capacity, even though this is false and the nominal current has not yet been reached.

Note: Please contact HygroMatik if you wish to operate the unit

with softened water.

If using a water softening system, we recommend diluting the softened water with normal tap water to produce an overall hardness between 4-8°dH. This value can be set lower if the water does not foam.

When blending softened water with deionized water (conductivity = 5-20 µS / cm) it is to ensure that the mixture neither foams nor is too low in conductivity.

When feed water contains softened water, the level of conductivity is typically higher at operating temperature. Install a HygroMatik "cylinder star" to extend the service life of the electrodes.

6.2 Water Supply

- » Install a shut-off valve (SV) in the supply line.
- » Install a water filter (WF) if water quality requires it.



Note: Shut-off valve (SV) and water filter (WF) are not supplied with the unit

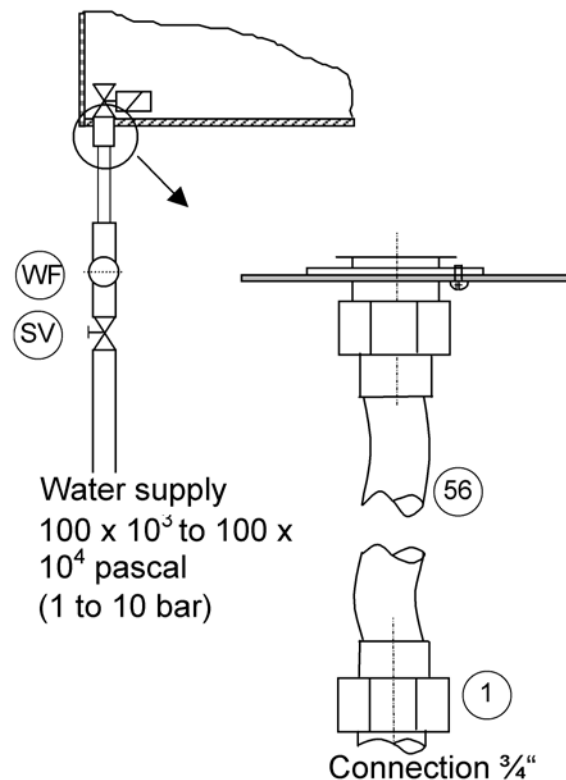

- » HygroMatik provides a water hose (56) with a cap nut at both ends which can be used for water installation.

Install as follows:



- » Screw and tighten the cap nut with its inner seal ring around the water supply screw connection that protrudes from the base.

Note: Tightening too much will destroy the fitting. The valve

strainer must be placed inside the solenoid valve.

- » Use a cap nut (internal thread 3/4") with inner seal for a customer-provided water installation.

6.3 Water discharge



Warning: During blow down hot water with a temperature of about 95°C is being drained. If touched this can cause burns to the skin.



Warning: Pay attention for free and non-pressure drainage of the water! During blow down up to 0,3 L/sec are being drained. For water discharge, we recommend installation of a flexible water drain hose. Humidifier and wastewater discharge must be on the same pressure level.

Please note:

- Do not bend the drain hose.
- Install discharge line and drain pipe made from temperature resistant material (to 95° C).

Install water discharge as follows

- Install a drain hose 1 1/4 ", 250 - 1000 mm long, into a pressure-free outlet according to DIN EN 1717. Please ensure that ascending vapor does not condensate on the humidifier`s housing.
- Fit water drain hose over the pump drain hose and fasten to the housing drain connection.

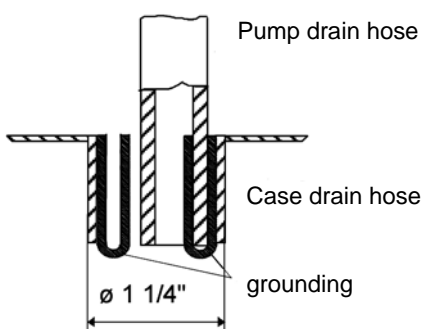

2 grounding clips are fixed on the inner surface of the housing drain connection. During blow-down, the grounding clip is in direct contact with the water and shunts potential residual electric currents away from the housing.

There is a 3mm-wide crack between the pump drain hose jacket and the inner surface of the housing drain connection. If water collects in the base plate, it will flow through this crack into the drainage system.

6.4 Water Installation Check

Go down the following water installation checklist:

- Are all screws and clamps properly tightened?
- Is the water supply pipe flushed?
- Was the water installation correctly installed?
- Can the blow-down water drain freely?
- Was the water discharge correctly installed?
- Is there no leakage from the water supply pipe and water discharge?



Warning: Flush the water supply pipe before connecting to the solenoid valve, especially a newly installed pipe. This prevents premature damage.

7. Electrical Connection



Danger, Hazardous Voltage: All work related to electrical installation to be performed by authorized personnel only (electricians or professionals with equivalent training). The customer is responsible for checking qualifications.



Danger, Hazardous Voltage: Do not plug the steam humidifier into the power grid until after all installation work has been completed.



Warning: The electronic components of the humidifier control are very sensitive to electrostatic discharges. In order to protect these components during any type of installation, steps must be taken to guard against damage from electrostatic discharge (ESD protection).



Warning: For electrical installation, note the following:

- Disconnect power supply before installation and protect against restart.
- Verify the absence of electric current.
- Make sure the unit is switched off before installing or removing the display plate or basic PCB.
- Professionally lay electrical connector cable.
- Install the electrical connections according to the wiring diagram.
- For units with rated power over 33 kW, only a permanent connection to a permanent wire is allowable (German Association for Electrical, Electronic & Information Technologies [VDE] Standard 0700 Section 98).
- Verify that all terminals have been tightened.

7.1 Electrical Installation

- » Fuses must have a contact gap of at least 3mm per pole.
- » Install a separate main connection for each steam cylinder, complete with main contactor, main switch, etc.
- » Connect potential equalization to the outer ground bolt.
- » Observe the German Association for Electrical, Electronic & Information Technologies [VDE] Standard 0100 when selecting a connection cross section.
- » Install main power supplies as follows:

Type	Standard Main Power Supply
HY05 - HY45	1 x 400V/3Phase/N
HY60 - HY116	2 x 400V/3Phase/N
C01, C02	1 x 230V/1Phase/N
C06 - C58	1 x 400V/3Phase/N
MS5, MS10	1 x 400V/3Phase/N
MS5	1 x 230V/1Phase/N
C01Kit, C02Kit	1 x 230V/1Phase
C06Kit - C45Kit	1 x 400V/3Phase/N

Other voltages are available on request.

We recommend employing medium blow main fuses (applicable only to the grid voltages above). See table below indicating maximum power usage for each circuit protection:

When using fault current circuit breakers please use a separate one for the humidifier.

HyLine:

Type	Power Usage	Circuit Protection
HY05	5,4 A	3 x 6A
HY08	8,7 A	3 x 10A
HY13	14,1 A	3 x 16 A
HY17	18,4 A	3 x 20 A
HY23	24,9 A	3 x 35 A
HY30	32,5 A	3 x 35 A
HY45	48,8 A	3 x 63 A
HY60	2 x 32,5 A	6 x 35 A
HY90	2 x 48,8 A	6 x 63 A
HY116	2 x 62,8 A	6 x 63 A

CompactLine:

Type	Power Usage	Circuit Protection
C01	3,3A	1 x 6A
C02	6,5A	1 x 10A
C06	6,5 A	3 x 10 A
C10	10,8 A	3 x 16 A
C17	18,4 A	3 x 20 A
C22	23,8	3 x 35 A
C30	32,5 A	3 x 35 A
C45	48,8 A	3 x 63 A
C58	62,8 A	3 x 63 A

MiniSteam:

Type	Power Usage	Circuit Protection
MS5, 230V/1/N	15,7 A	1 x 16 A
MS5, 400V/3/N	5,4 A	3 x 6 A
MS10, 400V/3/N	10,8 A	3 x 16 A

CompactLine KIT:

Type	Power Usage	Circuit Protection
C01KIT, 230V/1/N	3,3 A	1 x 6 A
C02KIT, 230V/1/N	6,5 A	1 x 10 A
C06KIT, 400V/3/N	6,5 A	3 x 10 A
C10KIT, 400V/3/N	10,8 A	3 x 16 A
C17 KIT, 400V/3/N	18,4 A	3 x 25 A
C30KIT, 400V/3/N	32,5 A	3 x 35 A
C45KIT, 400V/3/N	48,8 A	3 x 63 A

7.2 Cable Connections

The table below shows the cable connections provided in electrode steam humidifiers:

Unit	Connection M16	Connection M25	Connection M32
HY05, HY08	4	3	-
HY13, HY17, HY23, HY30, Hy45	4	2	1
HY60, HY90, HY116	-	4	2
C01, C02	4	1	-
C06	3	2	-
C10	3	3	-
C17, C30	4	3	-
C45, C58	4	2	1
MS5, MS10	-	2	-

Characteristics of metric cable connections:

Thread	across-flats dimensions [mm]	for cable diameter [mm]
M16x1,5	19	4,5 - 10
M25x1,5	30	9 - 17
M32x1,5	36	11 - 21

7.3 Safety Interlock



Note: Install contact interlocks, i.e. max. hygostat, vane relay, pressure controller, air interlock, in series between terminals 1 and 2.



Warning: A max-hygostat should be installed in the safety interlock. The max-hygostat acts as a safety device in case the humidity sensor malfunctions.



Warning: Contacts laid between terminals 1 and 2 must be potential free and rated for 230V switches.

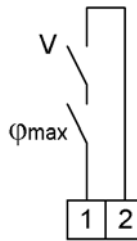

7.4 Wiring Diagram

Please remove the wiring diagram from the technical manual supplied with the control used with your humidifier. Every steam humidifier comes with one technical manual for the unit and one for the control.

7.5 Electrical Installation Checklist

Perform electrical installation checks in compliance with customer site requirements and public power utility regulations:

- Is the power grid voltage compatible with the voltage on the name plate?
- Have all electrical connections been made according to the terminal connection diagram?
- Have all electrical cable and plug connections been properly tightened?
- Are all electrical socket connections secure?
- Is the unit grounded?

After this check the unit can be switched on.



Warning: The unit must be closed and locked. This guarantees that the cover is grounded. (only humidifier type HyLine and MiniSteam)



Note: For initial operation, control, service, malfunctions, and circuit diagrams, consult the operation instructions for the Hygro-Matik-controls.

8. Maintenance

The HygroMatik steam humidifier is easy to maintain. However, inadequate or improper maintenance can lead to operational malfunctions. Perform regular maintenance to give your unit a long life span.



Warning: When performing maintenance work, please note:

- During operation and also for a while after switching off the unit the steam cylinder is hot. Before touching the cylinder, check its temperature.
- Drained cylinder water could have a temperature up to 95°C.
- Leakages within the humidifier could lead to leakage currents.
- The unit is only to be serviced by qualified, authorized personnel.
- Observe safety notes.
- Switch off the unit before maintenance and protect against restart.
- After maintenance work, have qualified personnel check that the unit is operating safely.

The steam humidifier's performance and maintenance intervals primarily depend on the water quality (carbonate hardness, conductivity) and the quantity of steam produced since the last maintenance. Abnormal water quality can shorten or lengthen maintenance intervals. Ongoing maintenance intervals can be estimated based on the amount and type of residue found in the steam cylinder.

Indications that cylinder maintenance is required immediately include:

Control	Indicator
Basic	maintenance message: red LED is blinking: Unit has switched itself off automatically.
Comfort Comfort Plus	Maintenance message on the display (red LED is blinking). Unit has switched itself off automatically*. The maintenance message can also be sent by one of the open programmable potentialfree contacts See EMP-Control Operation, Section "Parameter Settings with Codes"

* Also see corresponding control operation instruction, Section "Malfunctions".

Seals are wearing parts and must therefore be examined in the periodic maintenance and replaced if required.

8.1 Maintenance Work

Mineral deposits precipitate and crystallize very differently in different types of water, even when two types have the same conductivity and hardness levels (the various constituents in the water interact differently).

Instructions on maintenance and cleaning intervals, or on electrode service life, are based entirely on empirical data

Cycle	Maintenance Work
<p>4 Weeks after initial operation (with normal water quality)</p>	<p>Visual inspection of electrical and mechanical connections.</p> <p>Remove mineral deposits from steam cylinder, water drain hose and blow-down pump.</p> <p>Check electrodes for erosion.</p> <p>Retighten electrode hand nuts and all screw terminals</p>
<p>Semiannually (with normal water quality and "normal" operation = 8h/Day)</p>	<p>Visual inspection of electrical and mechanical connections.</p> <p>Remove mineral deposits from steam cylinder, water drain hose and blow-down pump.</p> <p>Check electrodes for erosion</p> <p>Retighten electrode hand nuts and all screw terminals.</p>

In most cases, the conductivity levels given in Section "Directions for Use" of these instructions can be considered normal. Individual parameter setting of the control may be necessary.

In extreme cases, water pretreatment may be necessary (softening by dilution to approx. 4 - 8 °dH; decarbonization/partial desalination to achieve target reductions in carbonate hardness).

For any question regarding water treatment systems please contact HygroMatik.

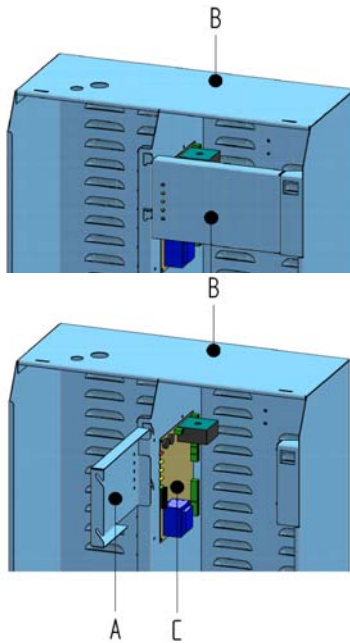

8.2 Access Electrical Enclosure

- » Remove cover from humidifier (B) and lift display plate (A) of guiding.
- » Turn display plate (please see sketch) and hang up display plate by using the „front guiding“.

- » The basic PCB (C) is now accessible.



Danger, Hazardous Voltage: Make sure the unit is switched off before installing or removing the display plate.

8.3 Removing and Cleaning the Steam Cylinder





Warning: Please follow the detailed instructions in these operating instructions! The unit is only to be serviced by qualified, authorized personnel. Note the warnings and safety notes in the operating instructions. Failure to observe warnings and safety notes may result in injury, serious injury or death, and/or damage to the unit. The steam cylinder may still be hot when you begin maintenance work. Handle carefully!



Warning: Both the clamps that fix the steam cylinder halves and the electrodes have sharp edges and angles that possibly could lead to cut injuries.

Disassembly

- » Switch on the unit by the main switch. The humidifier runs the pump for a few seconds. The purpose of this is to check that the system is operating properly.
- » Drain residual water in the cylinder.
- » Units with Basic, Comfort or Comfort Plus control electronics:
 - » Press the on/off control switch in position „II“.
 - » Units with Comfort or Comfort Plus control electronics:
 - » Press the Softwarekeys  and  simultaneously longer than 5 seconds.
 - » Open and remove cover.
 - » Disconnect the steam generator from the power supply. Control switch OFF and remove safety fuse F1.
 - » Check that unit is without power.
 - » Unscrew and remove the steam nozzle (1).
 - » Unplug the electrodes (4).
 - » Unplug the sensor electrode (10).
 - » Remove adapter (2) between steam cylinder and steam nozzle (1).

» then:

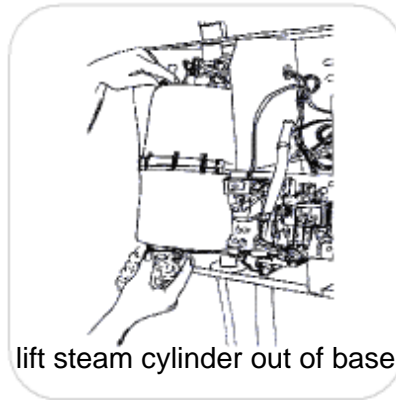

Cleaning

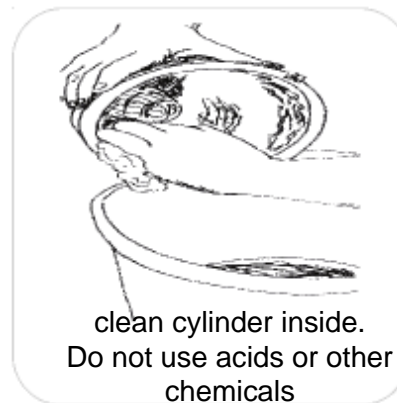

Warning: Check the inside of the top part of steam cylinder for crust build-up and possible salt bridges (black grooves between the electrode leads). If present, wash away completely .



Note: If electrical arcs have burned deep grooves in the material, the top part of the cylinder must be replaced.



Warning: Clean the sensor electrode until it is bright.

Reassembly

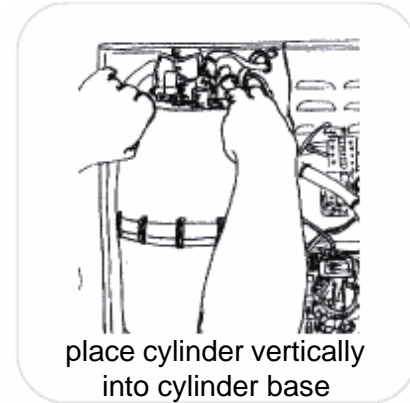
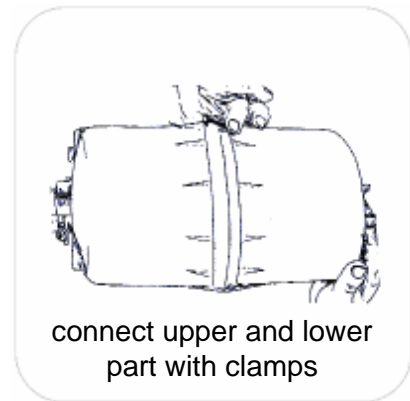

- » Connect plug (10) to level sensor.
- » Connect plugs (4) to electrodes.



Warning: The plug must be pressed down onto the electrode as far as it will go.



Note: Connect plugs to the correct electrodes. Note the color of the knurled nut.



Note: Condensate connection must be showing in the front on the left.

- » Push in safety fuses.

Switch on the unit and check for leaks after 15-30 minutes of operation.

If leakage occurs, switch off power supply and follow safety instructions for work on live components.

8.4 Electrode wear

Electrode wear depends on:

- feed water composition and conductivity.
- the quantity of steam produced.

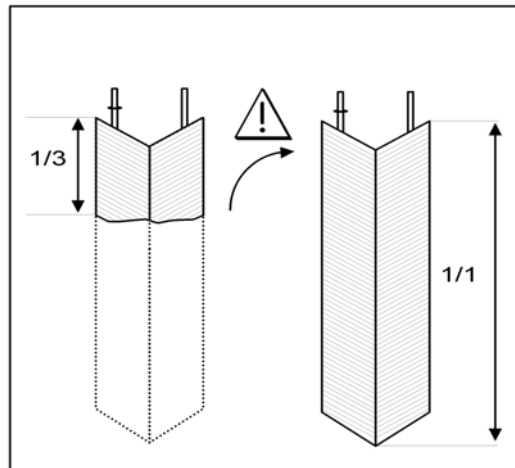

Warning: At the latest, electrodes must be replaced if a maintenance message is displayed. The maintenance message appears after one hour of operation at maximum water level. The humidifier switches itself off. Also see Section "Maintenance." When the electrodes are less than 1/3 to 1/2 of their original length, replace them.

8.4.1 Original Electrode Lengths

Original lengths of HygroMatik large area stainless-steel electrodes are:

HyLine:

Type	HY05-HY08	HY13-HY60	HY90-HY116
Length [mm]	155	235	300

CompactLine:

Type	C6	C10	C17-45	C58
Length [mm]	125	155	235	300

MiniSteam:

Type	MS5	MS10
Length [mm]	125	155

8.4.2 Uneven Electrode Lengths

In most case, the longer electrode(s) will not be supplied with electricity for a time. Therefore they will not wear. The cause of the problem, such as a tripped circuit breaker, can be repaired. However, since the shorter electrode(s) have a greater specific load, the electrodes continue to wear unevenly.



Note: Replace electrodes with significantly uneven wear. Check the power supply (breaker, voltage drop). Also see electronic operation, Section "Malfunctions."

8.5 Replacing Electrodes

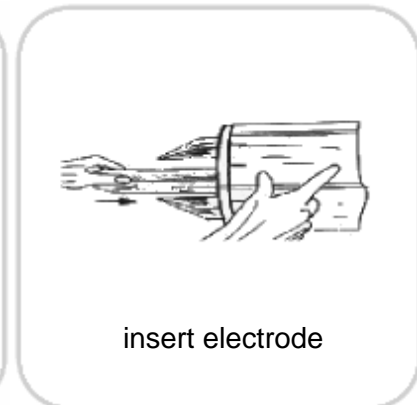
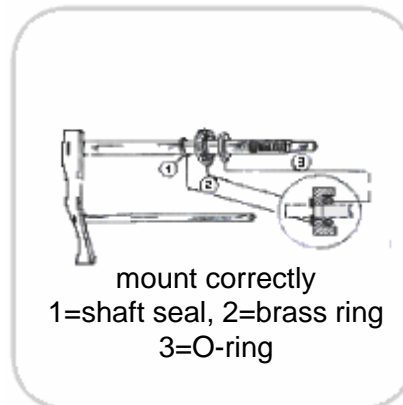
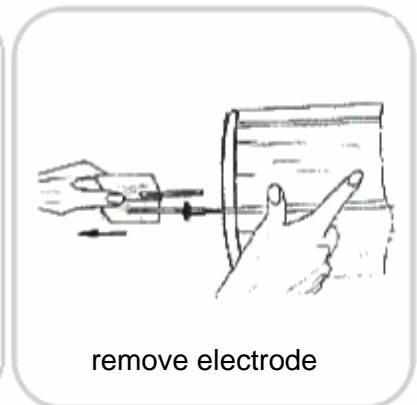

- » Remove cylinder, as described in Chapter 8.3 "Removing and Cleaning Steam Cylinder."
- » Loosen knurled nuts (5) and remove electrodes (48).
- » Install new electrodes and hand tighten the nuts.
- » Use solvent-free, HygroMatik-quality o-rings (for flange, cylinder base and steam hose adapter).
- » assemble steam cylinder and place it into housing.
- » Connect plugs (4) directly to the electrodes (48) (with gray, red and black knurled nuts). It is not necessary to detach the knurled nuts!



Warning: The plug must be pressed down onto the electrode as far as it will go.



Note: Connect plugs to the correct electrodes. Pay attention to the color or numbering of the knurled nut.

- » Attach plug (8) to the sensor electrode. (Knurled nut (9) - gray)
- » Switch breaker back on.
- » Switch on the unit and check for leaks after 15-30 minutes of operation.

If leakage occurs, switch off power supply and follow safety instructions for work on live components.



Note: In the following cases:

- the electrodes must be frequently replaced,
- black slime collects inside the cylinder, or
- there is "lightning" in the cylinder,

the conductivity of the water is too high or it isn't decanted often enough. In this case please contact HygroMatik.

8.6 Cleaning the Blow- Down Pump

- » Remove cylinder, as described in Section: "Removing and Cleaning the Steam Cylinder" .
- » Detach e-cable from the pump.
- » Detach adapter (30) from the pump.
- » Loosen screws (44) and remove the pump from the base.
- » Open the pump (bayonet lock).
- » Remove residues from the drain hoses and pump (potentially replace o-ring (33) or housing (34) if these components are no longer in excellent condition).
- » Reassemble the pump.
- » Moisten o-ring (31) and insert in the side connection of the base.
- » Push pump into the base and mount tightly with screws (44).
- » Moisten o-ring (31) and insert in adapter (30).
- » Fit adapter (30) over the side connection of the pump.
- » Connect e-cable to the pump.
- » Install cylinder,
- » Switch on the unit and check for leaks during operation.

If leakage occurs, switch off power supply and follow safety instructions for work on live components.

8.7 Cleaning the Water Inlet Solenoid Valve

Removal

- » Shut off water supply.
- » Remove cylinder, as described in Section: "Removing and Cleaning the Steam Cylinder" .
- » Loosen water installation hose connection.
- » Loosen connecting hose (21) from the base.
- » Detach e-cable from the solenoid valve.
- » Loosen solenoid valve mounting screws (28).
- » Remove solenoid valve from the borehole.
- » Remove fine mesh filter (29) from the solenoid valve, clean and replace if needed.

Installation

- » Insert fine mesh filter (29).
- » Place solenoid valve with seal in the borehole of the

unit housing.

- » Attach solenoid valve tightly with screws (28).
- » Screw on water installation hose.
- » Connect e-cable to the solenoid valve.
- » Attach connecting hose (21) to the base.
- » Install cylinder, as described in Section: "Removing and Cleaning the Steam Cylinder"
- » Turn on the tap.
- » Switch on the unit and check for leaks during operation.

If leakage occurs, switch off power supply and follow safety instructions for work on live components.

8.8 Checking Cable Connections and Electrode Cables

- » Make sure that no cable and plug connections are loose.



Warning: Plugs must be pressed down onto electrodes as far as they will go.

Loose cable connections cause excessive contact resistance and overheating of contact surfaces.

- » Check electrode plug isolation, replace plugs as needed.



Warning: Replace electrode plugs after removing and reinstalling them several times.

8.9 Checking Operation

Start up the unit and operate for a few minutes at maximum output if possible.

- » Check safety devices.
- » Check hose connections for possible leaks.

8.10 Dismantling

After you stop using the steam humidifier, dismantle (demolish or scrap) it by following the installation procedures in reverse order.



Warning: Dismantling of the unit is only to be attempted by qualified personnel. Electrical dismantling is only to be attempted by trained professionals.

Note the information provided in Section 2 "Safety Notes," especially the guidelines for disposal.

9. Commissioning



Warning: This unit is only to be started by qualified personnel.

Switching off steam humidifier



Warning: Before starting up the unit, make sure you know how to switch it off.

- » Switch off unit by setting control switch to “0”
- » Close water supply stopcock valve.

Check of electrical wire connections

- » Check that all electrical wire connections, including heater element wire connections, are tight and secure.
- » Check cylinder seating, and if necessary steam and condensate hose clamps.

Switching on Steam Humidifier

- » Switch on main breaker.
- » Open water supply stopcock valve. Operating pressure 100×10^3 to 100×10^4 Pa (1 to 10 bar overpressure).
- » Switch on unit by setting control switch to “1”.
- » Set control of initial operation check to humidity demand.

The following functions are operating:

- The unit performs a self-test. If the control includes a display, the message “self-test” is displayed.
- When there is a demand for humidity, the water inlet solenoid valve opens and feeds water into the steam cylinder.
- Initiation of steam production can take up to 20 minutes.

Let all electrically-driven operations run to completion.

As soon as the solenoid valve begins replenishing the water periodically, the steam humidifier operates at steady nominal output and the cold start sequence is complete.

- » Monitor the unit and let it operate for 15 to 30 minutes. If leaks appear, switch off the unit.
- » Repair leaks, and in doing so:



Attention, Hazardous Voltage! Follow safety instructions for work on live components.

10. EC-Declaration of Conformity

EG-Konformitätserklärung EC Declaration of Conformity

Hersteller: **HygroMatik GmbH**
Manufacturer: *HygroMatik GmbH*

Anschrift: Lise-Meitner-Straße 3
Address: *D-24558 Henstedt-Ulzburg / Germany*

Produktbezeichnung / Product description:

Hy-Line: HY05, HY08, HY13, HY17, HY23, HY30, HY45, HY60, HY90, HY116

C-Line: C01, C02, C06, C10, C17, C22, C30, C45, C58

MiniSteam: MS05, MS10

In den Ausführungen / Type: Basic, Comfort, Comfort Plus, Dampfbad / *Steam bath (DS)*

Die bezeichneten Produkte stimmen in der von uns in Verkehr gebrachten Ausführung mit den Vorschriften folgender Europäischer Richtlinien überein:

The products described above in the form as delivered are in conformity with the provisions of the following European Directives:

2004/108/EG Richtlinie des Rates zur Angleichung der Rechtsvorschriften der Mitgliedstaaten über die elektromagnetische Verträglichkeit.

Council Directive on the approximation of the laws of the Member States relating to electromagnetic compatibility.

2006/95/EG Richtlinie des Rates zur Anleitung der Rechtsvorschriften der Mitgliedstaaten betreffend elektrische Betriebsmittel zur Verwendung innerhalb bestimmter Spannungsgrenzen.

Council Directive on the approximation of the laws of the Member States related to electrical equipment designed for use within certain voltage limits.

Die Konformität mit den Richtlinien wird nachgewiesen durch die Einhaltung folgender Normen:

Conformity to the Directives is assured through the application of the following standards:

Referenznummer:	Ausgabedatum:	Referenznummer:	Ausgabedatum:
<i>Reference number:</i>	<i>Edition:</i>	<i>Reference number:</i>	<i>Edition:</i>
DIN EN 55022	2008-05	DIN EN 60335-1	2007-02
DIN EN 61000-4-2	2001-12	DIN EN 60335-1/A13	2009-05
DIN EN 61000-4-3	2008-06	DIN EN 60335-2-98	2009-04
DIN EN 61000-4-4	2005-07	DIN EN 62233	2008-11
DIN EN 61000-4-5	2007-06	DIN EN 62233 Ber.1	2009-04
DIN EN 61000-4-6	2008-04		

Die Anforderungen des Geräte- und Produktsicherheitsgesetzes (GPSG) §4 Abs. 1 bis 3 werden eingehalten. Eine vom Lieferzustand abweichende Veränderung des Gerätes führt zum Verlust der Konformität. *The requirements of the German Appliance and Product Safety Law (GPSG) paragraph 4 clause 1 to 3 are met. Product modifications after delivery may result in a loss of conformity.*

Henstedt-Ulzburg, den / the 04.10.2011

HygroMatik GmbH



Dirc Menssing
General Manager



Dr. Andreas Bock
Technical Manager

Diese Erklärung bescheinigt die Übereinstimmung mit den genannten Richtlinien, ist jedoch keine Zusicherung von Eigenschaften. Die Sicherheitshinweise der mitgelieferten Produktdokumentation sind zu beachten. *This declaration certifies the conformity to the specified directives but contains no assurance of properties. The safety documentation accompanying the product shall be considered in detail.*

11. Spare Parts

*	MS5	MS10	Article no.	Description
			E-2124010	Keys for safety, set=2pc.
			E-2124012	Safety lock incl. 2 keys
Steam generation				
	1		B-3216067	Steam cylinder CY4 transp. compl. with electrodes and Hand nuts **
		1	B-3204031	Steam cylinder CY8 transp. compl. with electrodes and Hand nuts **
16	1		E-3216043	Top part of steam cylinder CY4 empty
16		1	E-3226005	Top part of steam cylinder CY8 empty
19	1		B-3216044	Lower part of steam cylinder compl. with strainer **
19		1	B-3216007	Lower part of steam cylinder compl. with strainer **
17	1		E-3216046	O-ring seal for cylinder flange, transparent cylinder
17		1	E-3216010	O-ring seal for cylinder flange, transparent cylinder
35	1	1	E-3216011	O-ring seal for cylinder base
12	1		E-3216020	Condensate plug DN 9
12		1	E-2204035	Condensate plug DN 12
11	1	1	E-2304014	Hose clamp 10-16mm Torro
48	1		B-3216061	Electrodes compl. with hand nuts, set=3pc.
48		1	B-3204019	Electrodes compl. with hand nuts, set=3pc.
10	1		B-3204037	Sensor electrode compl. with hand nut, max. limitation
10		1	B-3204027	Sensor electrode compl. with hand nut, max. limitation
4	1	1	E-3216024	Plug-in contact with insulating hose for electrodes
10	3	3	E-3216025	Plug-in contact with insulating hose for sensorelectrode
18	12	12	E-3216022	Clamp for flange of transparent cylinder
37	1	1	E-3220000	Cylinder base DN 20/25/15/12
	1		B-3117015	Fan 60x120 mm
		1	E-3117012	Fan 60x180 mm
1	1		E-3126048	Steam nozzle
1		1	E-3126130	Steam nozzle
2	1		E-3126054	Adapter between steam cylinder and steam nozzle
2		1	E-3720008	Adapter between steam cylinder and steam nozzle
38	0,41m	0,84m	E-2604002	Condensate hose steam nozzle - cylinder base DN12, per m
	1		B-3216077	maintenance kit for cylinder CY 4
		1	B-3216079	maintenance kit for cylinder CY 8
		(1)	B-2304063	Super Flush -upgrade kit-
Water feed				
25	1		B-2304081	Solenoid valve, servo controlled, straight type, 0,2-10 bar, 1,2l/min
25		1	B-2304083	Solenoid valve, servo controlled, straight type, 0,2-10 bar, 2,5l/min
		1	B-2304021	Solenoid valve, long-life, servo controlled, straight, 0,2-10bar,2,5l/min
56	1	1	B-2304031	Hose for water connection, 3/4" cap nuts on both sides
49	1	1	E-3616010	angle piece 90°, reducing DN14/12
20	1	1	E-2304080	earthing bush
21	0,71m	0,90m	E-2604002	Connecting hose, solenoid valve - reduction, per m
26	0,05m	0,05m	E-2604004	Connecting hose, reduction - cylinder base, per m
22	7	7	E-2304015	Hose clamp 10-16mm
39	2	2	E-8501064	Hose clamp 12-20mm
24	0,06m	0,06m	E-2604002	Connecting hose solenoid valve - bush for earthing
20	1	1	E-2304080	Bush for earthing
58	1	1	E-2604094	double check valve

*	MS5	MS10	Article no.	Description
Water drain				
15	0,3m	0,4m	E-2604002	Connecting hose pump-elbow
30	1	1	E-3425002	Adapter pump - drain hose. connections DN25/13
31	1	1	E-3220005	O-ring seal for adapter - pump
31	1	1	E-3220005	O-ring seal for cylinder base - pump
32	1	1	B-2404027	Drain pump without mounting set
14	0,36m	0,45m	E-2604004	Connecting hose elbow-drain
57	1	1	E-2420423	Drain hose, 1 1/4", per m
	1		B-3401015	Drain hose system (pos. 6, 14, 15, 30, 31)
		1	B-3401017	Drain hose system (pos. 6, 14, 15, 30, 31)
6	1	1	E-2425004	Elbow with vent pipe
			B-2424014	Mounting set for drain pump (pos. 42-44)
Control universal				
	1	1	E-2501005	Main contactor 16 A, 230 V
	1	1	E-2507040	Only for CSA units: Main contactor 20 A, 230 V
	1	1	E-2505206	Control fuse 1,6 A, 5x20 mm
4	1	1	B-3526019	Connecting cables for electrodes with plug-in contact, set=3pc
8	1	1	B-2525051	Connecting cable for sensor electrode with plug-in contact, 630 mm
	x	x	E-0611001	Room hygrostat HG-Mini
Basic Control				
51	1	1	B-2526201	Basic mainboard
	1	1	E-2502412	control switch, 2 pole
52	1	1	B-2120901	Mountinig plate (Basic)
Comfort Control				
51	1	1	B-2526201	Basic mainboard
	1	1	E-2502412	control switch, 2 pole
52	1	1	B-2120903	Mounting plate (Comfort)
	1	1	B-2526401	Display (Comfort)
If you order any spare parts, please specify type and serial number of the unit.				
* Exploded view				
** If the Super Flush System is installed, consider to order also a new nozzle (B-2304079), please.				
*** Maintenance set consists of: electrodes (without hand nuts), o-ring for steam hose adapter, o-ring for cylinder flange, o-ring for cylinder base				

13. Technical Data

Technical Data Steam Humidifiers MiniSteam				
Type		MS5	MS5	MS10
Steam Output	[kg/h]	4,8	5	10
Electrical Supply		230V/1/N/50-60Hz	400V/3/N/50-60Hz	
Electrical Power	[kW][A]	3,6	3,8	7,5
Current		15,7	5,4	10,8
Fuse	[A]	1 x 16 *	3 x 6 *	3x 16 *
Control Type		Basic, Comfort		
Control Voltage		230V/50-60Hz		
Empty Weight	[kg]	12	12	15
Operation Weight	[kg]	15	15	19
Dimensions				
	Height	[mm]	490	580
	Width	[mm]	381	403
	Depth	[mm]	186	217
Water Supply		100 x 10 ³ to 100 x 10 ⁴ Pa (1 to 10 bar) incl. connection ¾"		
Water Drain		into funnel		
Air Circulation	[m ³ /h]	66		165
Sound Level (1m distance to the source of noise) [dB(A)]**	[dB(A)]	54	54	58
* Times 1.3 power input after Full Blow Down. If explosion fuses are used close to their specific limit we recommend to choose explosion fuses with a higher range.				
** During sporadic Blow Downs higher values.				

14. Exploded View

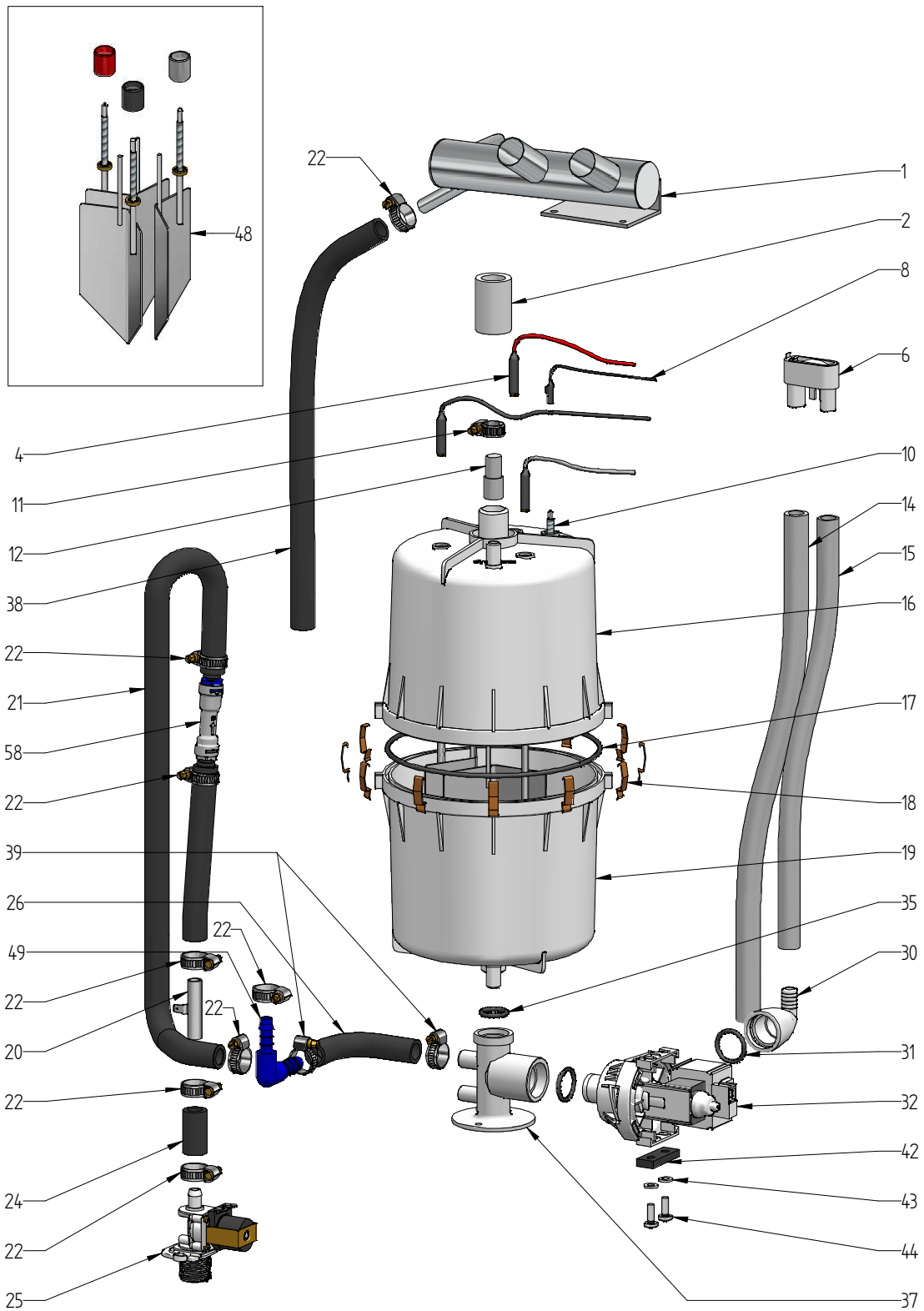

15. View of housing

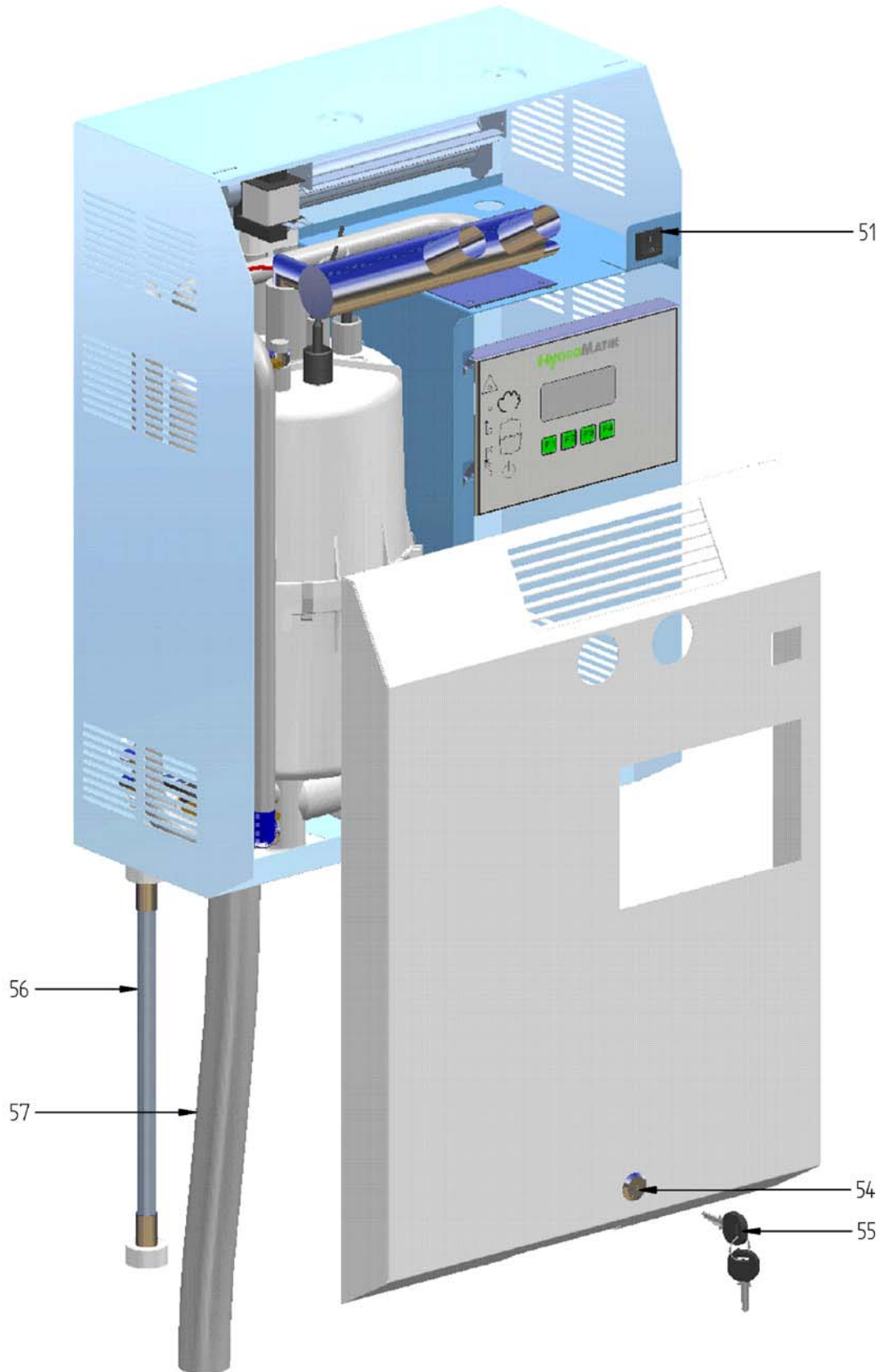



HYGROMATIK®

AIRTREND Limited

Predstavništvo u Beogradu

Kumanovska 14, 11000 Beograd

Tel: 011 383 68 86, 308 57 40

Faks: 011 344 41 13

e-mail: gobrid@eunet.rs

web: www.airtrend.rs