

HPS

Adiabatic humidification and cooling system

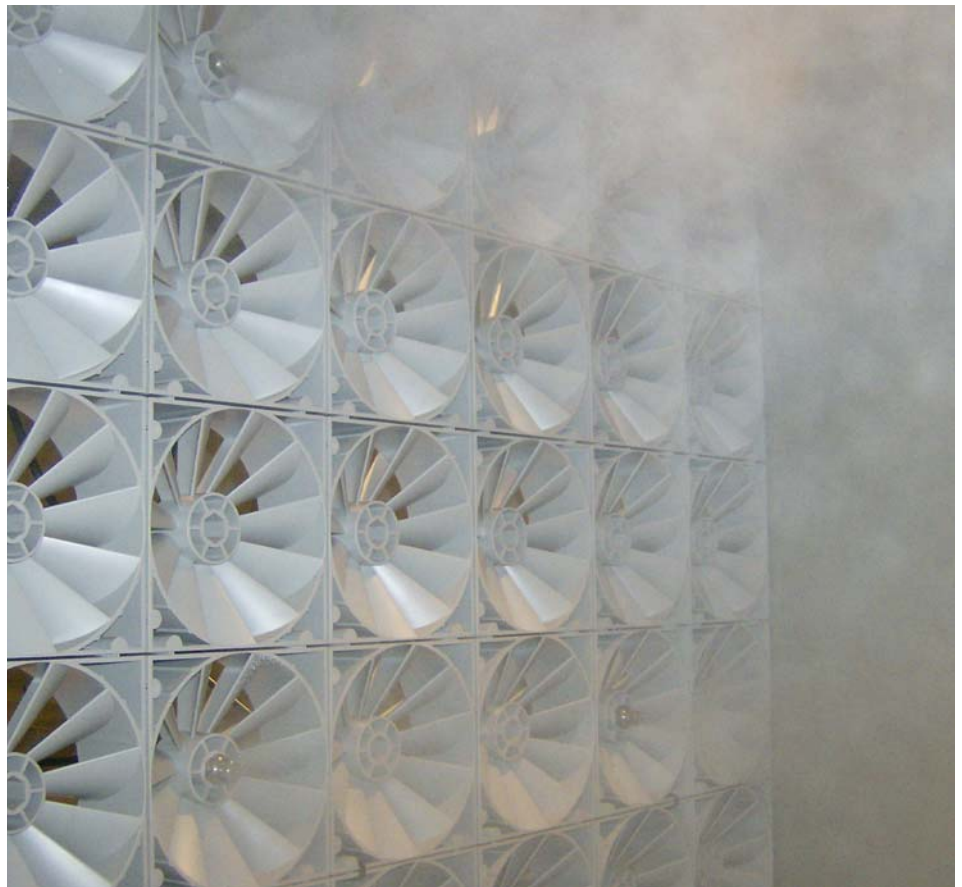

Certain computer programs contained in this product [or device] were developed by HygroMatik GmbH ("the Work(s)").

Copyright © HygroMatik GmbH [13.03.2019]

HPS EN

Current version of this manual can be found at: www.airtrend.rs

All Rights reserved.

HygroMatik GmbH grants the legal user of this product [or device] the right to use the Work(s) solely within the scope of the legitimate operation of the product [or device]. No other right is granted under this licence. In particular and without prejudice to the generality of the foregoing, the Work(s) may not be used, sold, licensed, transferred, copied or reproduced in whole or in part or in any manner or form other than as expressly granted here without the prior written consent of HygroMatik GmbH. Information in this manual is subject to change or alteration without prior notice.



Caution: Voltage: All work must be carried out by specialists. All electrical installation work and work on the device's electrical components must be carried out by authorised electricians. Switch off devices and disconnect them from the mains supply first!

1. Introduction	6
1.1 Typographic markings	6
1.2 Documentation	6
1.3 Intended use	7
2. Safety instructions	8
2.1 General information	8
2.2 Operational safety instructions	8
2.3 Disposal upon disassembly	9
3. Transport	10
3.1 General information	10
3.2 Packaging	10
3.3 Temporary storage	10
3.4 Inspecting for correctness and completeness	10
3.5 Scope of delivery	10
4. Function and design	11
4.1 Functioning	11
4.2 Design and process	11
4.2.1 High-pressure pump group	12
4.2.2 Dimension drawing of HygroMatik high-pressure nozzle system	12
4.2.3 Vortex modules	13
4.2.4 Atomising nozzles	14
4.2.5 Aerosol separators	15
4.2.6 Humidification section	15
5. Connections	16
5.1 Water	16
5.2 Waste water	16
5.3 High pressure water	16
5.4 Electrical	17
6. Interfaces to the HygroMatik high-pressure nozzle system	18
6.1 Air	18
6.2 Humidification chamber	18
7. Mechanical assembly	19
7.1 Overview on the humidification chamber	19
7.2 Housing of the high pressure nozzle system	20
7.3 Assembling the vortex module wall	20
7.3.1 Guide rails for the vortex module wall	20
7.3.2 Exemplary design of guide rails for a vortex module wall)	21
7.3.3 Side rails for the vortex module wall	22
7.3.4 Assembling of the side rails for the vortex module wall	22
7.4 Assembling the aerosol separators	23
7.4.1 Exemplary design of guide rails for the aerosol separators	23
7.4.2 Assembling two aerosol separators in a stack	24
7.5 Assembling of the distribution pipe	25

8. Water connection	27
8.1 Connection	27
8.2 Water quality	27
8.3 Water inlet	28
8.4 Water drain	28
8.4.1 Design of the water drain	28
8.4.2 Water drain for the humidification chamber	29
9. Water connection	30
9.1 Overview on water connection	30
9.2 Water supply	31
9.3 Drainage	32
9.4 Water drain for the humidification chamber	32
9.5 Water Quality	33
9.6 Inspection of water supply	33
10. Hygiene	34
10.1 Ensuring hygiene (VDI 6022)	34
10.2 Automatic flushing	34
11. Electrical connection	35
11.1 Connection data	36
11.2 System enabling / Safety chain	36
11.3 Circuit diagram	37
11.4 Inspecting the electrical installation	38
12. Commissioning	39
13. Device Control	40
13.1 Electrical and electronical components of the device	40
13.2 Control options (modes of operation)	41
13.3 Description of the control functions	43
13.3.1 Display and control unit	43
13.3.2 Switch on system	44
13.3.3 Menu structure	44
13.3.4 Reading values	45
13.3.5 Settings	45
13.3.6 Set time and date	46
13.3.7 Set language	47
13.3.8 Enter password (code)	47
13.3.9 Parameters (Code 010)	47
13.3.10 Fault history (Code 010)	49
13.4 Overview of error messages	49
13.5 Menu set-up and parametrisation	51
14. Maintenance	52
14.1 Maintenance activities	52
14.1.1 Changing the oil in the high-pressure pump	53
14.1.2 Checking/replacing the mains water filter	54

14.1.3 Flushing the mains water system	55
14.1.4 Cleaning the high-pressure nozzle	56
14.1.5 Cleaning the aerosol separators	57
14.1.6 Cleaning the vortex module wall	57
14.1.7 Cleaning the mounting profiles	57
14.1.8 Cleaning the humidification chamber	58
14.2 Extended HPS Service Manual	59
14.2.1 Replacing the shaft sealing ring of the high-pressure pump EH2009	59
14.2.2 Replacing the valves	61
14.2.3 Replacing the seals on the water side	62
15. EC declaration of conformity	63
16. Fax Form - Order for spare parts	64
17. Spare parts	65
18. Plant scheme	68
19. Technical data	69

1. Introduction

Dear Customer,

Thank you for purchasing a HygroMatik high-pressure nozzle system HPS.

The HygroMatik high-pressure nozzle system HPS corresponds to the current state of the art. It features exceptional operational reliability, ease of use and cost-effectiveness.

To ensure the proper, safe and economical operation of your HygroMatik high-pressure nozzle system HPS, please read this operating manual.

Only use the HygroMatik high-pressure nozzle system HPS if it is in perfect condition and only for its intended purpose, considering all safety and risk aspects as well as all instructions in this manual.

AIRTREND Limited

Predstavništvo u Beogradu

Kumanovska 14, 11000 Beograd

Tel: 011 383 68 86, 308 57 40

Faks: 011 344 41 13

e-mail: gobrid@eunet.rs

web: www.airtrend.rs

Please have your device data ready for queries or spare part orders!

1.1 Typographic markings

- lists with items beginning with bullets: general lists
- » lists with items beginning with arrows: work or operating steps which should or must be carried out in the specified order
- ☑ installation steps which must be checked
- italics* figure and plan names

1.2 Documentation

Storage

Please keep this operating manual in a safe place where it is accessible at all times. If you sell the product, be sure to include this manual. Please contact HygroMatik if the documentation is lost.

Language versions

This operating manual is available in different languages. Please contact your HygroMatik dealer or HygroMatik for details.

1.3 Intended use

The HygroMatik high-pressure nozzle system HPS is used for air humidification and cooling with desalinated water having a conductivity of 5-20 $\mu\text{S}/\text{cm}$. The feed water should have a temperature of 5-15°C.



Caution: Proper use includes fulfilment of the assembly, disassembly, reassembly, start-up, operating and maintenance conditions specified by us as well as disposal measures.

Only appointed qualified staff may work on or with the system. Persons transporting or working on or with the system must have read and understood the relevant parts of this operating manual, particularly the 'Safety instructions' section. Staff must also be informed of possible hazards by the operating company. Please keep a copy of the operating manual at the location where the device is being used.

The HygroMatik high-pressure nozzle system HPS is not frost-proofed and not suitable for outdoor installation.

The room temperature should be between 5 and 40°C.

Applications:

The HygroMatik high-pressure nozzle system HPS has a wide range of applications. These systems are used wherever low-energy adiabatic humidification or cooling or systems with high-precision control are needed. They can be found in such places as offices, storerooms, production halls, clean rooms, hospitals and concert halls.



Note: Components installed in ventilation and air-conditioning systems must be suitable for the intended use; i.e. they must be corrosion-resistant, easy to clean, accessible and hygienic. Furthermore, they must not facilitate growth of micro-organisms.

Improper use:

Hardware and software may not be modified.

2. Safety instructions

2.1 General information

The safety instructions are prescribed by law. They are intended to ensure health and safety at work and accident prevention.

Warnings and safety symbols

The following safety symbols are used in this manual to indicate hazard and risk warnings. Please familiarise yourself with these symbols.



Caution: Failure to heed this warning may result in injury or danger to life and limb and/or damage to the device.



Caution: Voltage: Dangerous electrical voltage! Failure to heed this warning may result in injury or danger to life and limb.



Caution: Failure to heed this warning may result in damage to the device from electrostatic discharge. The electronic components of the control system are highly sensitive to electrostatic discharge. To protect these components from damage by electrostatic discharge, special measures (ESD protection) must be taken during all installation work.



Note: indicates materials and consumables which must be handled and/or disposed of in accordance with statutory requirements.



Note: precedes explanations for or cross-references to other places in the text.

2.2 Operational safety instructions

General information

Observe all safety instructions and warnings found on the system.

If malfunctions occur switch the system off immediately and secure it to prevent it from being switched on. Eliminate the malfunctions immediately.

After maintenance work has been carried out, expert staff must ensure that the system is safe to operate.

Only use original spare parts.

National regulations beyond the scope of this manual apply without restriction for operation of this device.

During operation of the HygroMatik high-pressure nozzle system it is not allowed to stay in the humidification chamber.

The desalinated water used for feeding the HygroMatik high-pressure nozzle system is unsuitable for drinking.

Work on the high pressure components of the nozzle system is only allowed if the unit is disconnected from the power supply.

Accident prevention regulations



Caution: Heed the HSW (Health and Safety at Work) regulations for electrical installations and equipment (VBG4/BGVA3).

By doing so you protect yourself and others from harm.

Operating the HygroMatik high-pressure nozzle system

Refrain from all work practices which compromise the safety of the system.

Check all protection and warning devices at regular intervals to ensure they are in perfect working order.

Do not remove or deactivate safety devices.

Assembling, disassembling, servicing and maintaining the device

Disconnect system parts from the mains supply before servicing or repairing them.

Mounting or insertion of **additional devices** is only permitted with the **written consent** of the manufacturer.

Electrical equipment



Caution: Only a qualified electrician is permitted to work on the electrical system and the control cabinet.

Disconnect system parts from the mains supply before working on them.

Switch off the system immediately if faults in the electrical energy supply occur.

Only use original fuses with the specified amperage.

Inspect the system's electrical equipment at regular intervals. Promptly eliminate deficiencies, such as loose connections or melted cables. After carrying out the corresponding electrical assembly or maintenance work, test all protective measures used (e.g. earth resistance).

The HygroMatik high-pressure nozzle system is protected to IP22. Ensure that the devices are protected from dripping water at the installation location.

If a HygroMatik high-pressure nozzle system is to be set up in an area without water drainage, safety measures which eliminate the possibility of water entering the system due to leaks must be taken.

2.3 Disposal upon disassembly



Note: The operating company is responsible for disposal of the system parts in accordance with statutory requirements.

3. Transport

3.1 General information



Note: Take care when transporting the HygroMatik high-pressure nozzle system to prevent the device and packaging from being damaged by impact or accidental loading or unloading.

3.2 Packaging



Note: The HygroMatik high-pressure nozzle system is delivered on a pallet.

3.3 Temporary storage

Store the material in a clean dry place. The storage temperature should be 0-40°C.



Note: Only clean components may be installed in a ventilation duct.

3.4 Inspecting for correctness and completeness

When you receive the goods, ensure that:

- the equipment is complete and all parts are in perfect condition.



Note: Any transport damages and/or missing parts must be reported immediately to the shipper or supplier.

The periods in which notification of the transport company must occur for the purposes of identifying the damage are as follows*:

Transport company	Time after receipt of goods
Post	no later than 24 hours
Rail	7 days at the latest
Rail and road transport companies	4 days at the latest
Parcel services	immediately

* Periods are subject to change without notice.

3.5 Scope of delivery

The following items are included in the delivery:

- vortex modules
- aerosol separators
- high-pressure pump station
- operating instructions for the system.



Note: Hoses and nozzles are delivered at the time of start-up.

4. Function and design

4.1 Functioning

The HygroMatik high-pressure nozzle system is based on atomisation of water.

Desalinated water is fed into a high-pressure piston pump. With an operating pressure of up to 75 bar, the water is atomized by means of high-pressure nozzles. These nozzles generate a very fine spray mist which is taken up by the air in the humidification chamber. The ambient air is cooled adiabatically in the process.

4.2 Design and process

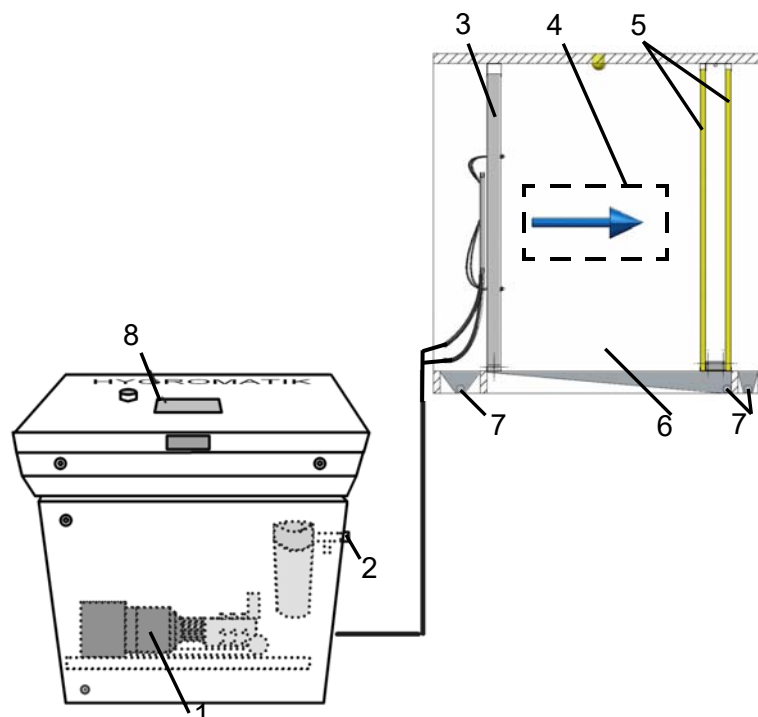

- 1: Pump group
- 2: Water feed
- 3: Vortex module wall
- 4: Viewing window (necessary according to VDI 6022)
- 5: 2-stage aerosol separator
- 6: Humidification chamber or duct with service doors and water tray
- 7: Water drain, siphoned
- 8: SPS-control



Note: The swept area of the control cabinet door may not be changed.

Note: Short piping distances:



To avoid loss of pressure, the piping path for the water should be as short as possible and have the lowest possible height difference.

4.2.1 High-pressure pump group

The high-pressure piston pump generates a pressure of up to 75 bar. The maintenance-free asynchronous motor with variable frequency and voltage enables continuous 9-50 Hz operation.

Pump group	Humidification output* [kg/h]	Max. speed [rpm]
HPS250	46-250 (14-180 with Bypass)	1400
HPS500	90-500 (65-390 with Bypass)	1400

*: with an efficiency rate of 98%

4.2.2 Dimension drawing of HygroMatik high-pressure nozzle system

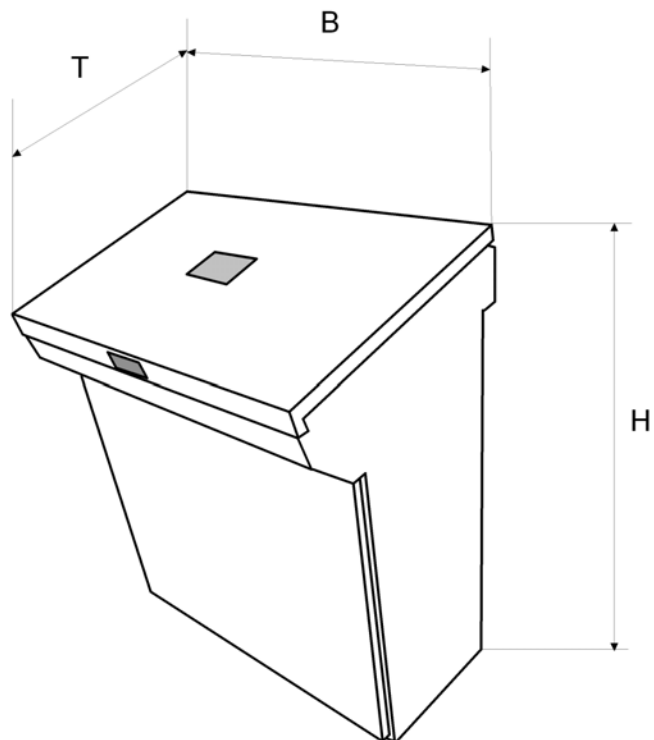

	H	T	B	
HPS250	990	480	850	approx 60 Kg
HPS500	990	480	850	approx 80 Kg

4.2.3 Vortex modules

The vortex modules provide for effective mixing of the air and water mist.

Due to their special design, they generate turbulence and shear zones which lead to a homogeneous distribution of moisture along the humidification section (0.9 m).

The vortex modules (dimensions: 150 x 150 mm) are delivered individually and can be assembled to form a wall. For optimal moisture absorption, the air velocity is 1.0-2.5 m/s. The vortex module wall exhibits a low pressure drop of 20 Pa at an air velocity of 2.0 m/s.

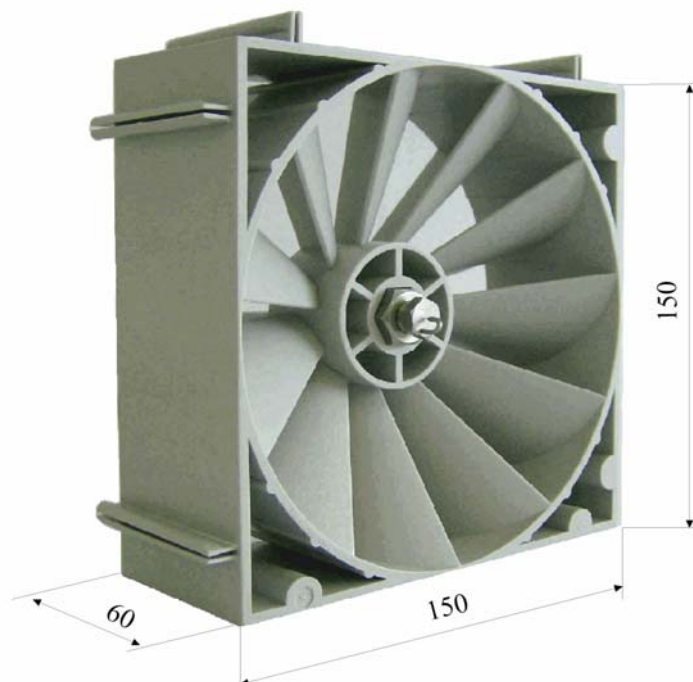
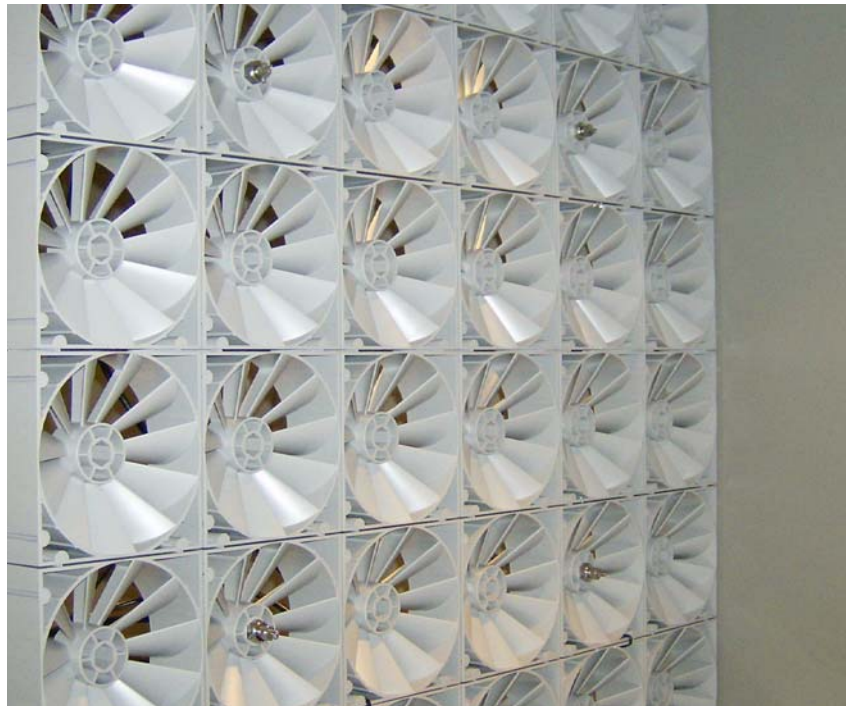

4.2.4 Atomising nozzles

Desalinated water at a pressure of 25-75 bar reaches the high-pressure nozzles where the water is atomised to form ultra-fine mist-like aerosols. The aerosols enter the area of the vortexed air stream downstream of the vortex modules. The air and aerosols are mixed intensively here.

Normally two different types of atomising nozzles are used: On the one hand there are atomising nozzles with an aperture angle of 120° , on the other hand atomising nozzles for the edge area of the vortex module wall with an aperture angle of 60° exist.

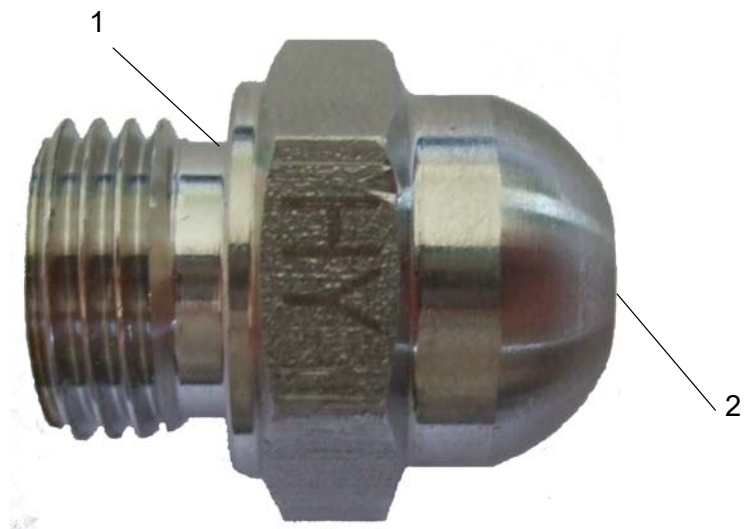

1: Nozzle body

2: Nozzle opening

Functioning:

Water is forced with high velocity into circulation by the swirl insert of the nozzle. Thereby the required atomisation of water into extremely fine aerosols takes place at the outlet opening.

The high operating pressure of the water (up to 75 bar) is nearly completely translated into the exit velocity from the nozzle. The higher the operating pressure the finer the droplets.

High-pressure nozzle material: stainless steel 1.4404

Spray characteristics at operating pressure of 75 bar

Volumetric flow rate: [l/h] 7,1*

Most droplets with diameter between 6-35µm at 75bar.

(*: Information is subject to change or alteration without prior notice)

4.2.5 Aerosol separators



aerosol separators

There are no more atomised water droplets in the air stream behind the HygroMatik high-pressure nozzle system (if the environmental parameter specifications are complied with). The two wire-mesh aerosol separators arranged in series ensure this. The trap pads exhibit a low pressure drop (60 Pa at air velocity of 2.0 m/s and average air density of 1.2 kg/m³).

The air velocity should be between 0.9 m/s and 2.8 m/s. If it is outside this range it can cause moisture breakthrough downstream of the aerosol separators - in such cases please first contact HygroMatik.

The aerosol separators are inserted into the humidification chamber via guide rails and are hence easy to remove for servicing.

4.2.6 Humidification section

The section between the vortex module wall and the aerosol separators is called the 'humidification section' in this system. It is unobstructed and hence easy to monitor and clean.

For a total standard installation length of 1.5 m for the HygroMatik high-pressure nozzle system the humidification section should have a length of at least 0.9 m. The exact dimensions are shown in the schematic in the section entitled 'Overview of the humidification chamber'.

5. Connections

5.1 Water

Connection:	3/4"-external thread
Conductivity:	5-20 $\mu\text{S/cm}$
Pressure:	0.1-0.5 MPa (1-5 bar)
Temperature:	max. 15°C
pH value:	7 +/- 1



Note: The supply water for the HygroMatik high-pressure nozzle system must comply with VDI 6022; i.e. from a microbiological point of view it must be of drinking water quality.

5.2 Waste water

Connection:	Plastic hose DN 12
Fitting:	with constant fall and with siphon

5.3 High pressure water

Connections for loads:	3/8"-external thread for high-pressure hose
-------------------------------	---------------------------------------------

5.4 Electrical

Power supply:	LNE 230 V AC, 50 Hz
External control signal:	0-10 V DC
System enabling:	via ext. potential-free contact
Collective fault signal:	potential-free contact (change over contact)
Operating status signal:	potential-free contact (NO)

6. Interfaces to the HygroMatik high-pressure nozzle system

6.1 Air

Air purity: A Class F7 pre-filter is to be placed upstream of the HygroMatik high-pressure nozzle system.

Air velocity: 0.9-2.8* m/s

If the air velocity is outside this range please contact HygroMatik.

(*: under ideal conditions)

Pressure drop: Approx. 80 Pa (at an air velocity of 2.0 m/s and with use of a vortex module wall and two dry aerosol separators).



Note: For humidification of rooms the humidified air must exhibit a purity in terms of bacterial count in accordance with VDI 6022.

6.2 Humidification chamber

The humidification component should be designed in the way of a scrubber housing featuring an inclination of at least 1.5° towards the trap and being waterproof.

The water drain must be situated at the end of the humidification section.

The ideal humidification section length (distance between vortex module wall and aerosol separators) is 0.9 m. This corresponds to a total installation length of 1.5 m (see schematic in section entitled 'Overview of the humidification chamber'). Should this installation length not be feasible, please contact HygroMatik.

The humidification chamber should be aerosol-tight and it should be able to withstand desalinated water.



Note: The guide rails for the vortex module wall and aerosol separators must be supplied by the manufacturer. The guide rails must already be installed before system start-up. Also, the vortex module wall and aerosol separators must already be installed.



Note: The guide rails must be designed such that the vortex module wall and aerosol separators can be removed (for servicing).



Note: Before start-up of the system check again that the humidification chamber has been thoroughly cleaned. In particular the humidification chamber and the ventilation duct upstream must be free from metal swarfs to prevent corrosion.

7. Mechanical assembly



Caution: The device may only be assembled by qualified staff. HygroMatik accept no liability for damages resulting from incorrect assembly.

Observe all safety instructions and warnings found on the device. The device must be de-energised during assembly.

Mounting or insertion of additional equipment is only permitted with the written consent of the manufacturer. Otherwise the guarantee and warranty will become void.

7.1 Overview on the humidification chamber

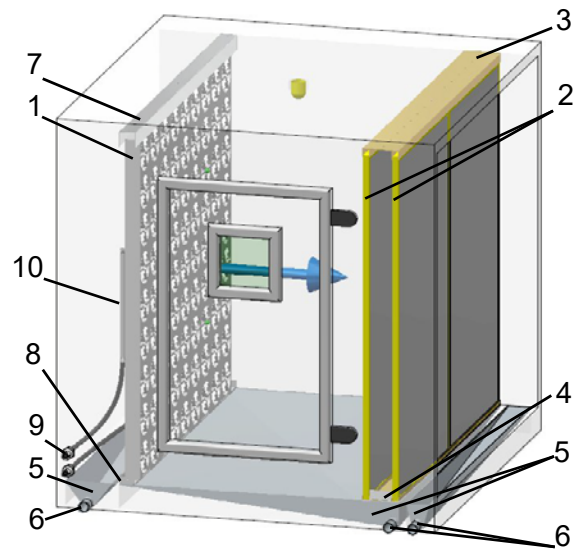

1: Vortex module wall with spray system

2: Aerosol separators

3: Upper guide rails for aerosol separators

4: Lower guide rails for aerosol separators

5: Collection tray

6: Drain with trap

7: Upper guide rails for vortex module wall

8: Lower guide rails for vortex module wall

9: Two M32 cable glands (for partial-load / full-load switching) for connecting high-pressure hoses. Only one cable gland is needed for the standard model.

10: Distribution pipe



Note: In front of the vortex module wall and from the aerosol separators a minimum distance of 0.3 m to other installed components must be maintained (see above schematic). Temperatures higher than 60°C may destroy the vortex modules.



Note: Between vortex module wall or droplet separator and a fan, a minimum distance of 1 m has to be observed. The air flow must be laminar.

7.2 Housing of the high pressure nozzle system

Screwing the housing of the high pressure nozzle system to the floor ensures a stable stand. For this purpose use the 12 mm drillings located in the four corners of the housing. A connection set is included in the scope of the delivery.

7.3 Assembling the vortex module wall

Two guide rails are required for the assembly of the vortex module wall.

We recommend to have an air gap sideways between the vortex module wall and the housing wall as it generates a laminar air flow and prevents moisture build-up on the walls.

7.3.1 Guide rails for the vortex module wall

In order to position the vortex module wall in the humidification chamber guide rails are required. The guide rails are fixed to the ceiling and the side walls of the humidification chamber.

The guide rails must be installed in a way that allows for lifting-up the vortex module wall.

Ensure that after installation the humidification chamber is leakage-free.

7.3.2 Exemplary design of guide rails for a vortex module wall)

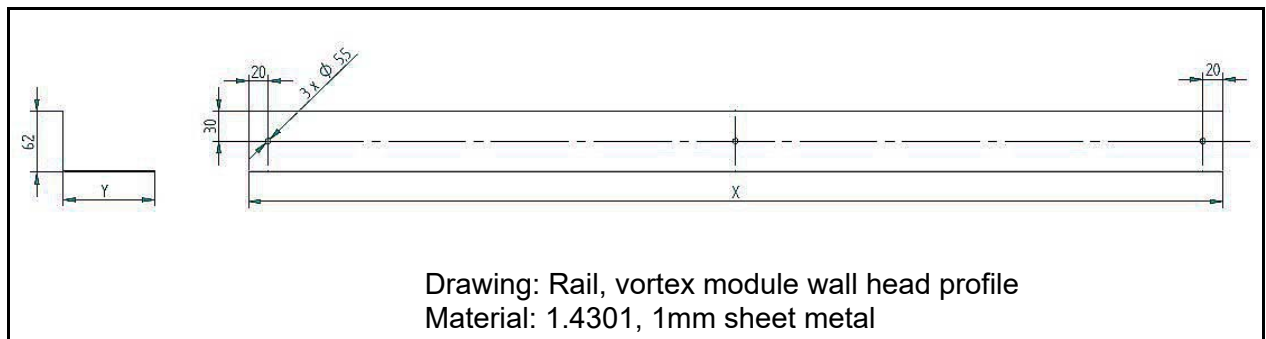
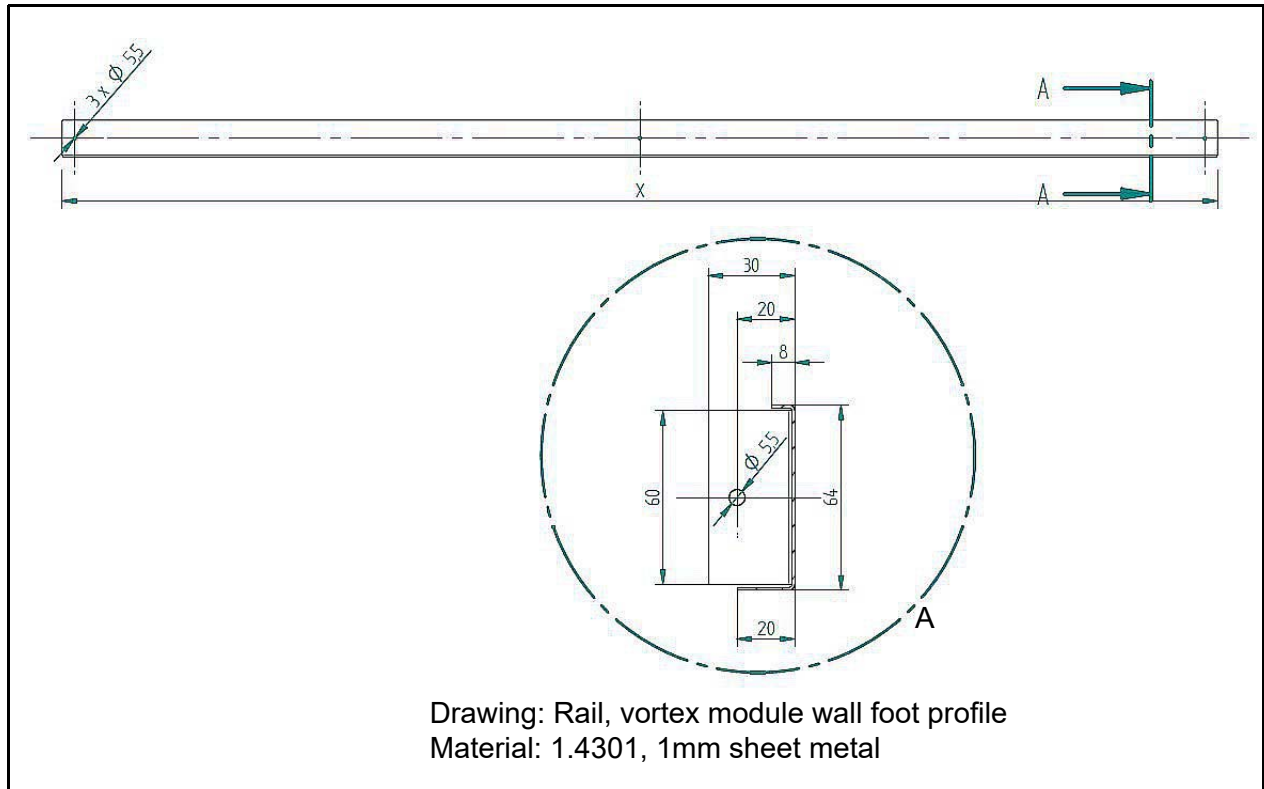

Note: A project specific drawing is offered in the context of the bid phase already.

7.3.3 Side rails for the vortex module wall

If the wall consists of 11 or more vortex module rows side rails are required in order to avoid bending of the vortex module wall.

In the case of more than 16 vortex modules in the horizontal dimension the the vortex module wall has to be vertically separated into two halves each of which is fixed fixed by its own side rails.

7.3.4 Assembling of the side rails for the vortex module wall

Vortex module walls consisting of 11 or more vortex module rows come with side rails and self-tapping screws. The side rails have to be adapted to the right length by the installer. The required length is the distance between the middle of the lowest and the middle of the top vortex module.

The side rail (1) is made of stainless steel and has an u-shape. The thickness is 1.5 mm. For assembling the open side of the u-section has to be attached to the lateral edge of the vortex module wall (3). The lower end of the side rail is positioned in the middle of the lowest vortex module. The lowest drilling (2) of the side rail is used to screw in a self-tapping screw (M3.9X20). A second self-tapping screw is used for the upper end of the side rail.

The side rail for the other side of the vortex module wall has to be assembled in the same way.

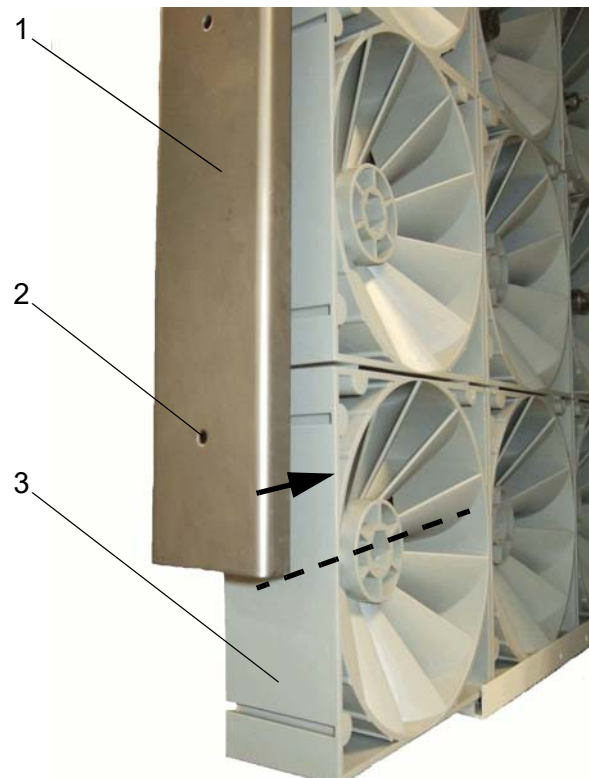

7.4 Assembling the aerosol separators

The guide rails must be installed in a way that allows for lifting-up the vortex module wall.

7.4.1 Exemplary design of guide rails for the aerosol separators

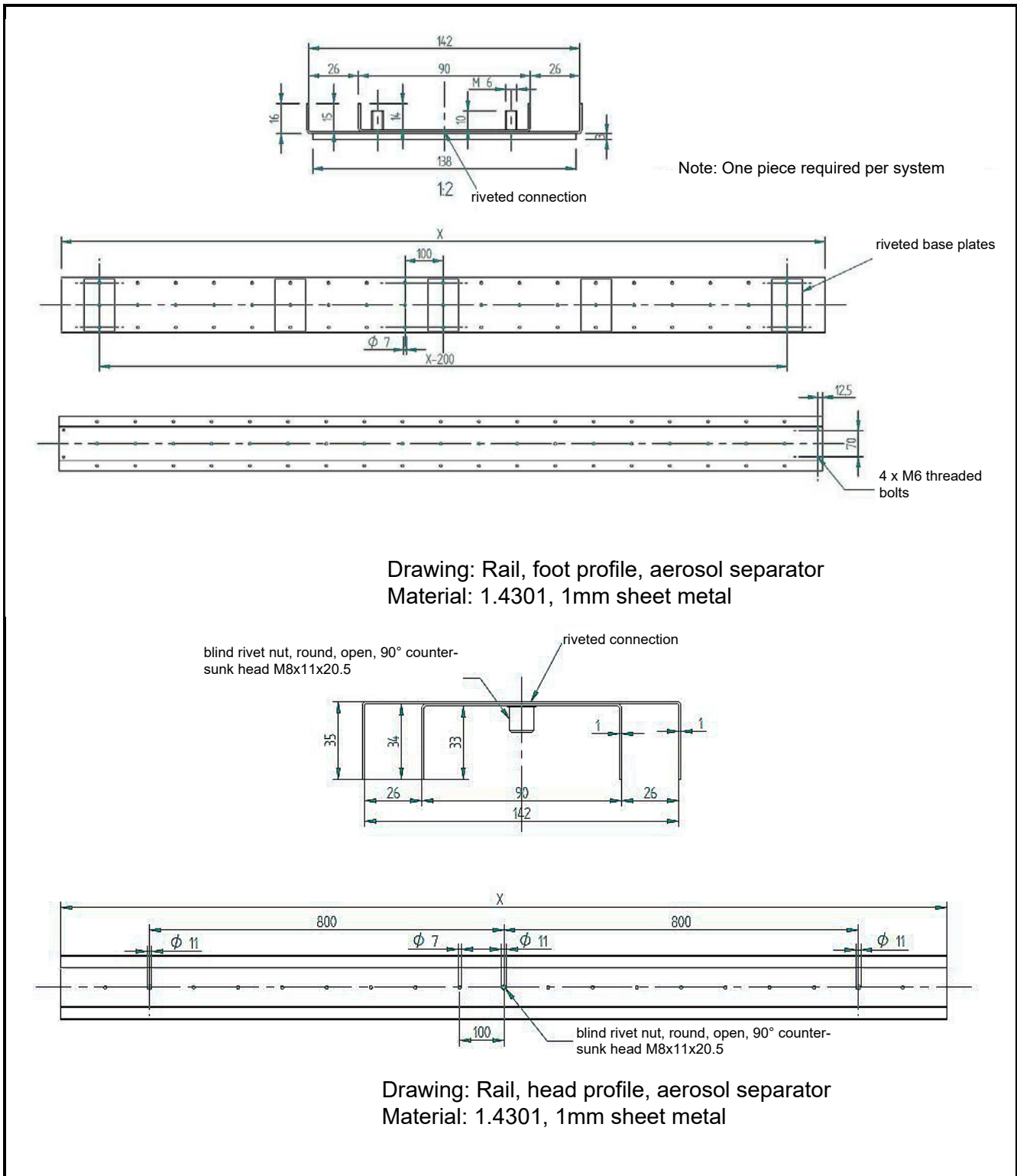

7.4.2 Assembling two aerosol separators in a stack

For installation heights of more than 1.5 m, two aerosol separators must be mounted in a stack.

The waste water from the upper aerosol separator is drained via an additional collector. For this the waste water from the upper trap is drained via a flexible hose either directly or into the collection tray. Such an additional collector has to be provided for both the first and the final aerosol separator.

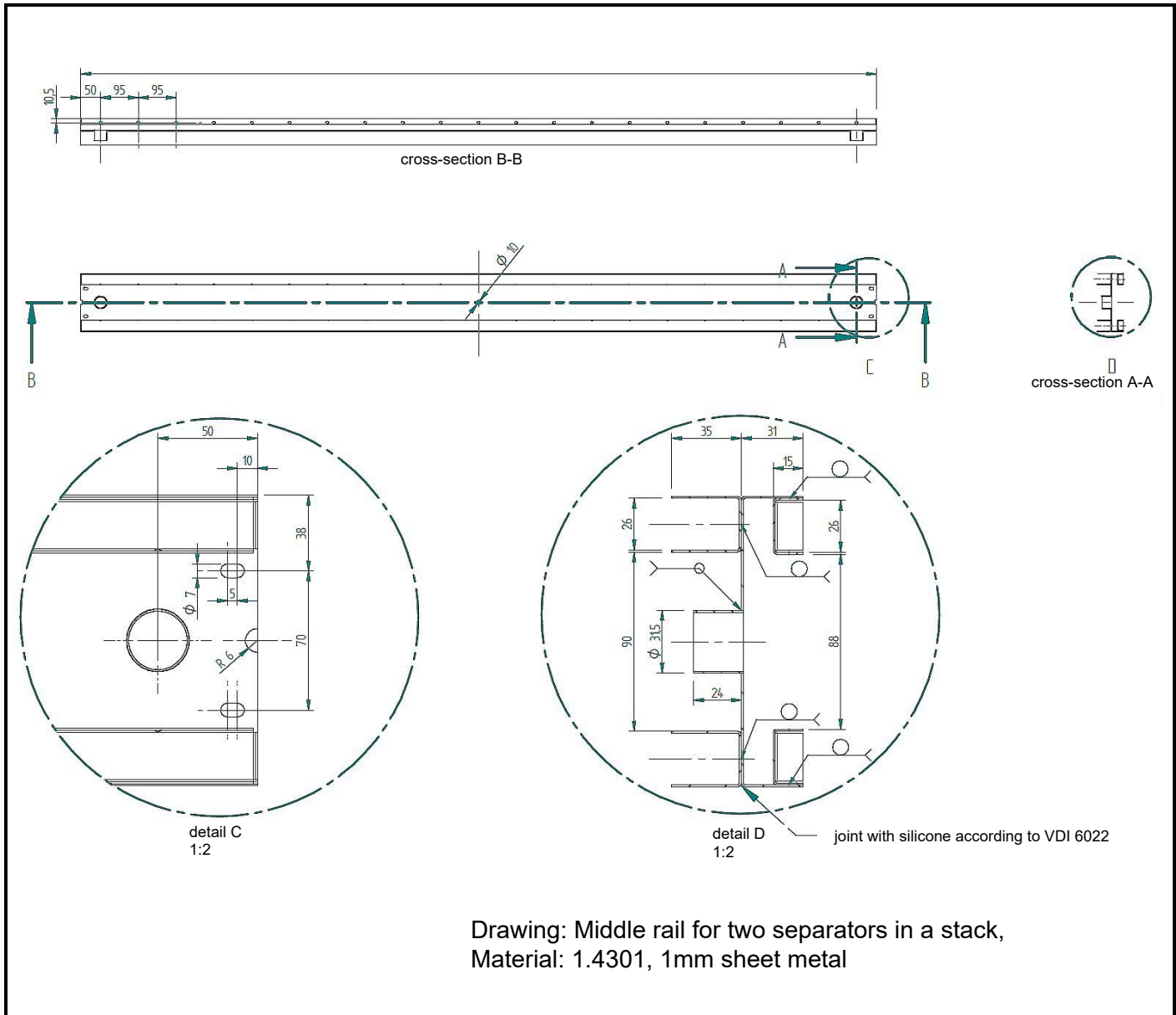

Note: A project specific drawing is offered within the bid phase already.

7.5 Assembling of the distribution pipe

The distribution pipe has to be attached to the vortex module wall in accordance to the assembling sketch that HygoMatik delivers for each project.

Each nozzle on the vortex module wall has to be connected to the distribution pipe by using a high pressure hose. Each nozzle has to be positioned on a higher level than its connection point at the distribution pipe - there should be a constant fall in the high pressure hose.

Assembling:

A distribution pipe is attached at least to two vortex modules.

On the upstream side of such a vortex module (1) a screw (2) with a washer (3) is inserted in the vortex module.

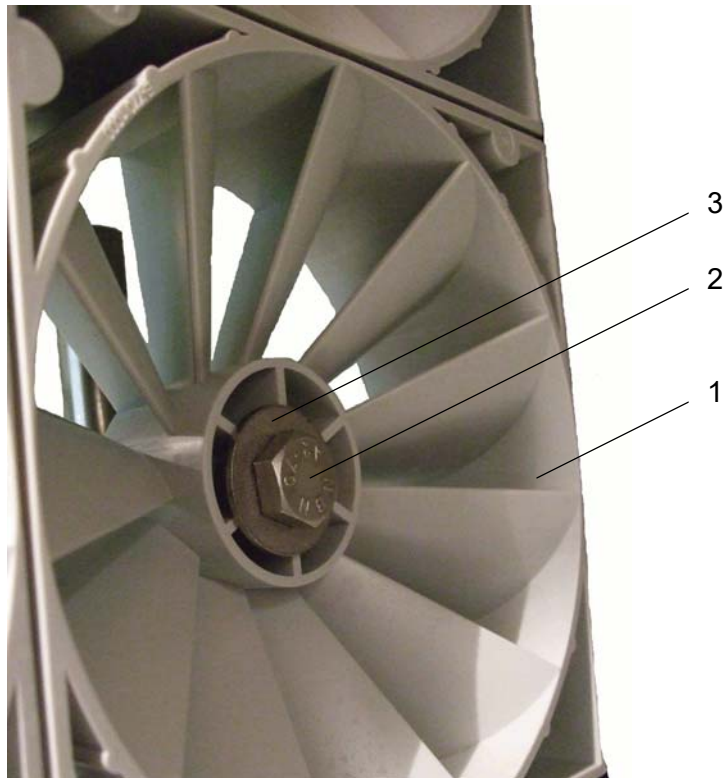

On the back side of the vortex module a washer (8) and another nut (4) are added to the screw (2). The nut has to be tightened.

Next step is to put a second nut (5), the distribution pipe (7) and a third nut (6) onto the screw.

Tightening the two nuts will fix the distribution pipe on the screw. The distance between vortex module and distribution pipe can be varied by changing the position of nuts (5) and (6).

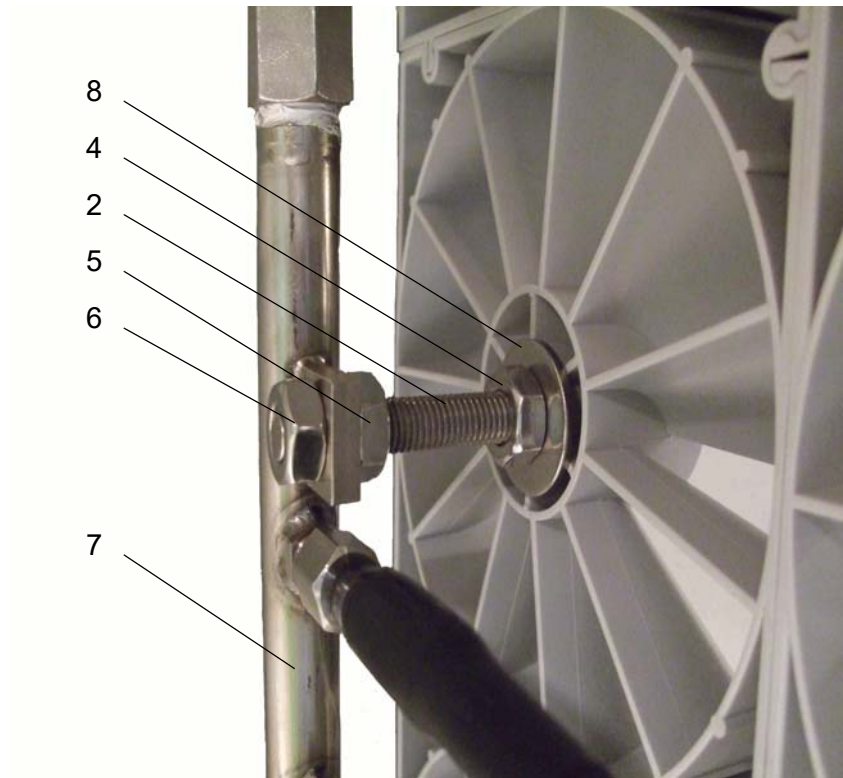

8. Water connection

8.1 Connection

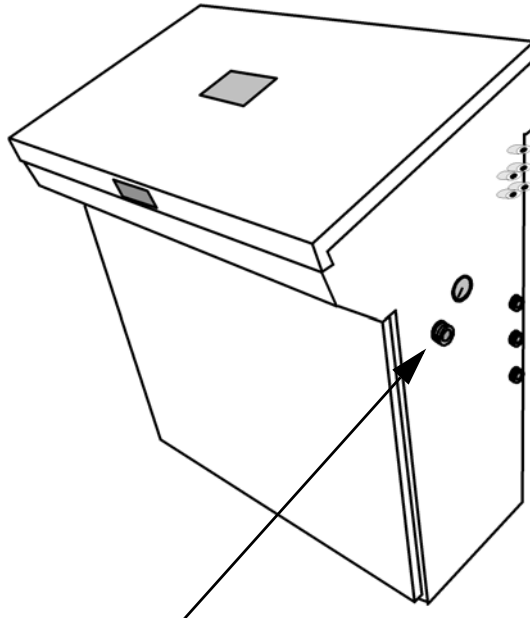

3/4"-external thread, right side of housing

Connection of the water supply is made at the high-pressure pump group's water inlet solenoid valve. There is a 3/4" external thread.



Note: We recommend designing the last segment of the water pipe to be flexible to prevent translation of vibration from the high-pressure pump group to the pipework.



Note: A stopcock in the direct vicinity of the HygroMatik high-pressure nozzle system is to be provided on-site.

8.2 Water quality

Conductivity:	5-20 $\mu\text{S/cm}$
Pressure:	0.1-0.5 MPa (1-5 bar)
Temperature:	5-15°C
pH value:	7 +/- 1

8.3 Water inlet

If desalinated water is used we recommend that stainless steel or plastic pipes be used.



Caution: During installation please bear in mind that:

- all work should be done by specialists only;
- the system must first be disconnected from the mains electricity supply
- local regulations of the waterworks or supply operations must be complied with.

8.4 Water drain

On the right side of the housing of the high pressure nozzle system DN12 plastic hose for draining is located. It is marked with „Drain”. This water drain is used to:

- empty and relieve the high-pressure lines to the vortex module wall after the enabling signal has been removed
- drain the flushing water from the feed water line in a flushing process

8.4.1 Design of the water drain

The plastic hose (connected to the HygroMatik high pressure nozzle system) has to be fed to the external drain. Ensure that the laying shows a constant fall and incorporates a siphon.

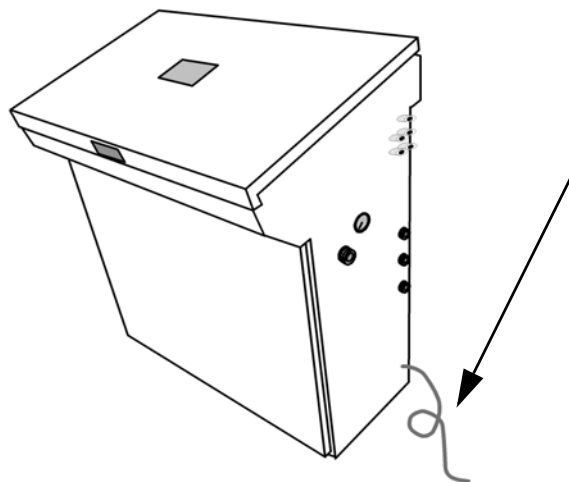

8.4.2 Water drain for the humidification chamber



Note: In the humidification chamber the water drain of a collection tray must be at the lowest point and be equipped with a siphon.

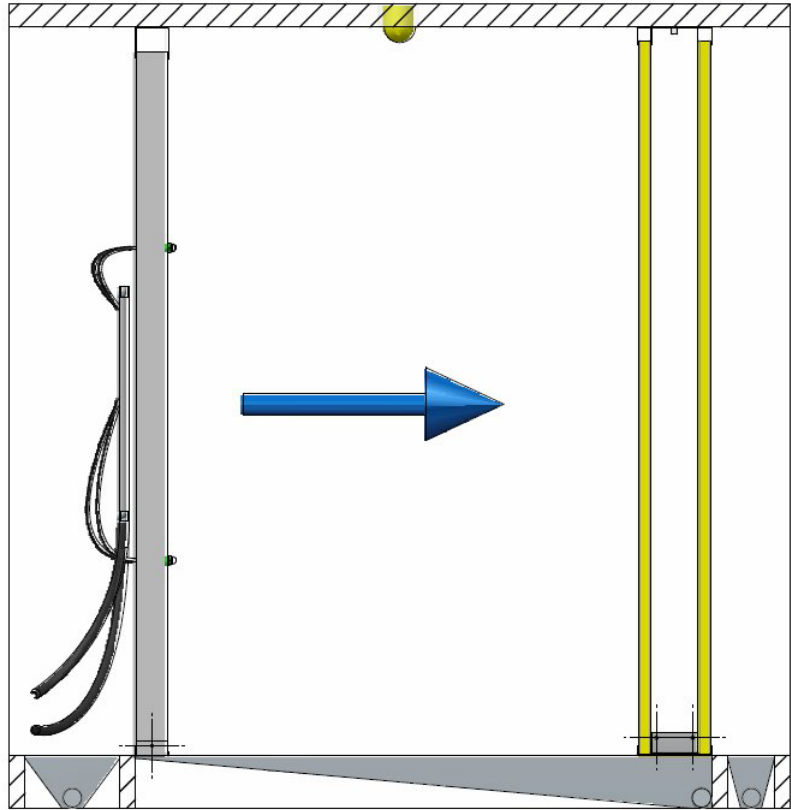

9. Water connection

9.1 Overview on water connection

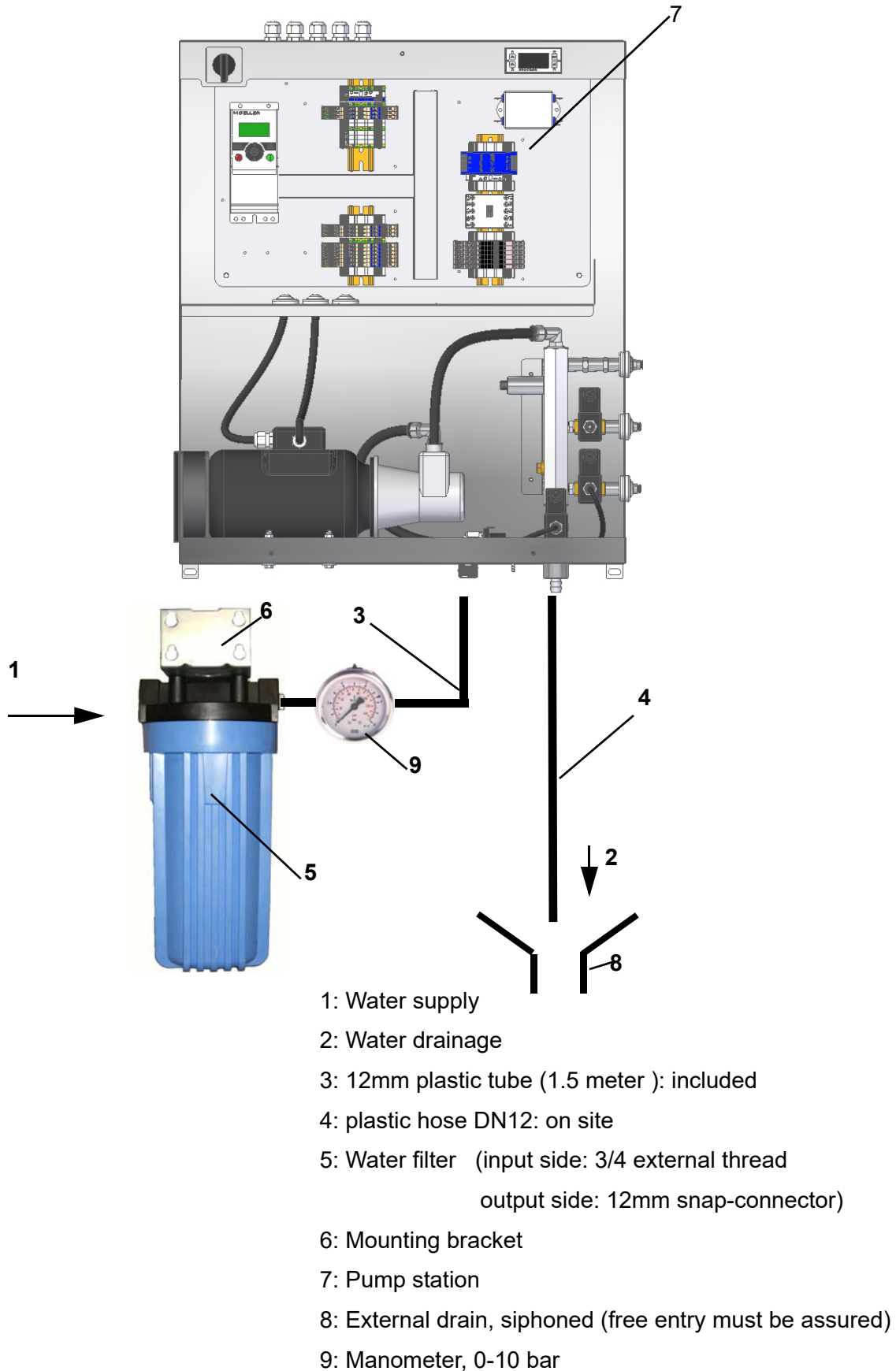



Note: There must be a stopcock and a sampling valve in the immediate vicinity of the HygroMatik LPS nozzle system provided.

9.2 Water supply



Attention: Please observe during installation:

- All work must only be performed by qualified personnel
- System must be switched off and voltage free
- Please observe local waterworks and utilities regulations

When using de-mineralized water we recommend the use of stainless steel or plastic pipes.

Water supply:

- » Locate water Filter (position 5 in the graph above) near the pump station (7)
- » Transfer mounting bracket hole pattern (6) to a suitable location on wall and drill holes
- » Using screws, rawlplugs and mounting brackets included with the water filter, fix water filter on wall
- » Connect T-piece and pump station water supply by means of water supply hose.
- » Connect the external feed water line to the input side of the water filter (3/4 "external thread)

9.3 Drainage

At the bottom of the housing, a DN12 spout is sticking out. This is a drain and is used to:

- empty and relieve the pressure lines to the vortex wall after removal of the module enable signal
- drain the flush water after flushing

Water drainage

- » A DN12 water hose (position 4 on the graph above) is attached to the DN12 spout on the bottom and made fast with a clamp
- » The tube is then siphoned off and installed on the slope to the drain (8).

9.4 Water drain for the humidification chamber



Note: The water drain in the collection tray must be at the lowest point in the humidification chamber.

It is recommended to have the water drain positioned downstream of the droplet separators with respect to the direction of air flow. Only in this way can the waste water drain completely.

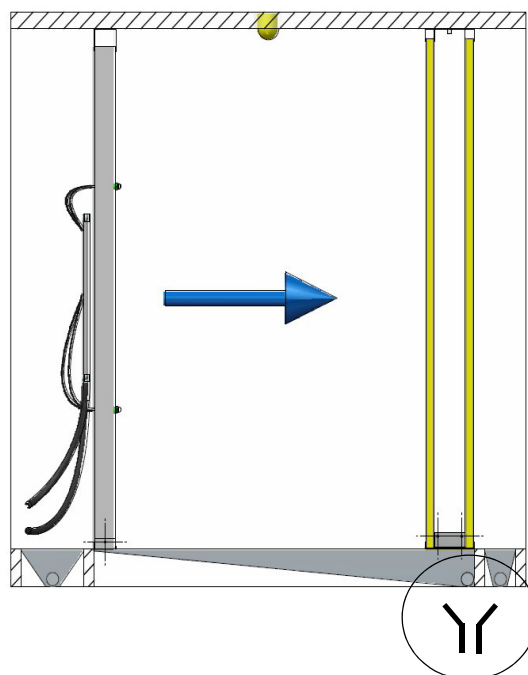

9.5 Water Quality

Conductivity:	5 - 50 μ S/cm
Pressure:	0.15 - 0.4 MPa (1.5 - 4 bar)
Flow rate	greater than max output of the nozzle system
Temperature:	5-15°C
PH value:	7 +/-1

9.6 Inspection of water supply

Water supply

- Is the supplied water filter installed to the water inlet for the pump station?
- Is the feed water quality within the specified range?
- Is the hose that lies between the water filter and pump station waterproofed?

Drainage

- Is the drain hose siphoned and installed with a constant decline to the drain?
- Can the flushing water drain off freely?

Humidification chamber

- Is the humidification chamber provided with a drain at the lowest point?

10. Hygiene

10.1 Ensuring hygiene (VDI 6022)

The regulations require that only inert materials must be used and biocides should only be used as a last option. Prior to humidification the supply air is to be purified using a Class F7 filter.

A metal filter made of mesh wire is used as a aerosol separator.

The aerosol separators can - if necessary - be easily cleaned and reused. Addition of a biocide is not required.

10.2 Automatic flushing

If the HygroMatik high-pressure nozzle system is in stand-by mode and there is no demand for operation for a period of 24 hours, the system will periodically run a flush cycle to obviate the growth of bacteria in standing water.

This flushing might lead to a momentary increase of humidity in an air conditioning system though no demand for humidifying may exist.

11. Electrical connection



Caution: Voltage! All electrical installation work must be carried out by qualified specialist staff (electricians or skilled workers with equivalent training) only. It is the customer's responsibility to monitor qualifications.



Caution: Voltage! All installation work must be completed before the HygroMatik high-pressure nozzle system is connected to the mains supply.

Please observe all local regulations for electrical installation work.



Caution: The electronic components of the HygroMatik high-pressure nozzle system control system are sensitive to electrostatic discharge. To protect these components from damage by electrostatic discharge, special measures must be taken during all installation work.



Caution: During installation please perform the following steps:

- Disconnect the system from the mains supply and secure it to prevent it from being switched on again.
- Ensure that the system is de-energised.
- Installation and removal of the control system may only be performed if the device is switched off.
- Lay electrical cables properly.
- Make the electrical connections according to the circuit diagrams.
- Ensure that all terminals are tight.
- Connect the system permanently to the supply network. The back-up fuses specified in the technical data must be used.



Note: For leakage currents of more than 35 mA a second PE conductor must be connected to the second PE terminal (use 2.5 mm² wiring in the case of protected installation or 4.0 mm² for unprotected installation).

11.1 Connection data

Power supply:	LNE 230 V AC, 50 Hz
External control signal:	0-10 V DC
System enabling:	via ext. potential-free contact
Group fault signal:	potential-free contact (change over contact)
Operating status signal:	potential-free contact (NO)



Note: If a residual current device is to be installed upstream of the system a universal-current-sensitive circuit-breaker should be selected.



Note: When sizing the connection lines, observe that the supply impedance must be low! If a short circuit occurs the circuit-breaker must switch off automatically within 0.4 s. The magnetic short circuit trigger for the circuit-breaker (type B) responds immediately when the flowing short circuit current is more than five times the rated current.

Pump group	Rated power [kVA]	Rated current [A]	Fuse [A]
HPS250	0.94	4.0	B20
HPS500	1.6	6.7	B32

11.2 System enabling / Safety chain



Note: Interlock contacts, such as max. hygostat, air flow relay, duct pressure switch, ventilator interlock etc., are placed in series between series terminals X2.1 and X2.2 (= safety chain).



Caution: If the ventilation system fails or the supply air face velocity is too low (less than 0.9 m/s) the built-in control must switch off the humidifier via the safety chain. Otherwise undesired condensate build-up behind the aerosol separator may occur.



Caution: Integration of a max. hygostat into the safety chain is state-of-the-art. The max. hygostat serves as a safety element in case of malfunction of the humidity sensor and protects against over-humidification.



Caution: The contacts across terminals X2.1 and X2.2 must be potential-free and suitable for switching 24 V DC / 100 mA. After the HygroMatik high-pressure nozzle system has been started, a voltage of 24 V DC is generally available at terminal X2.1.

11.3 Circuit diagram

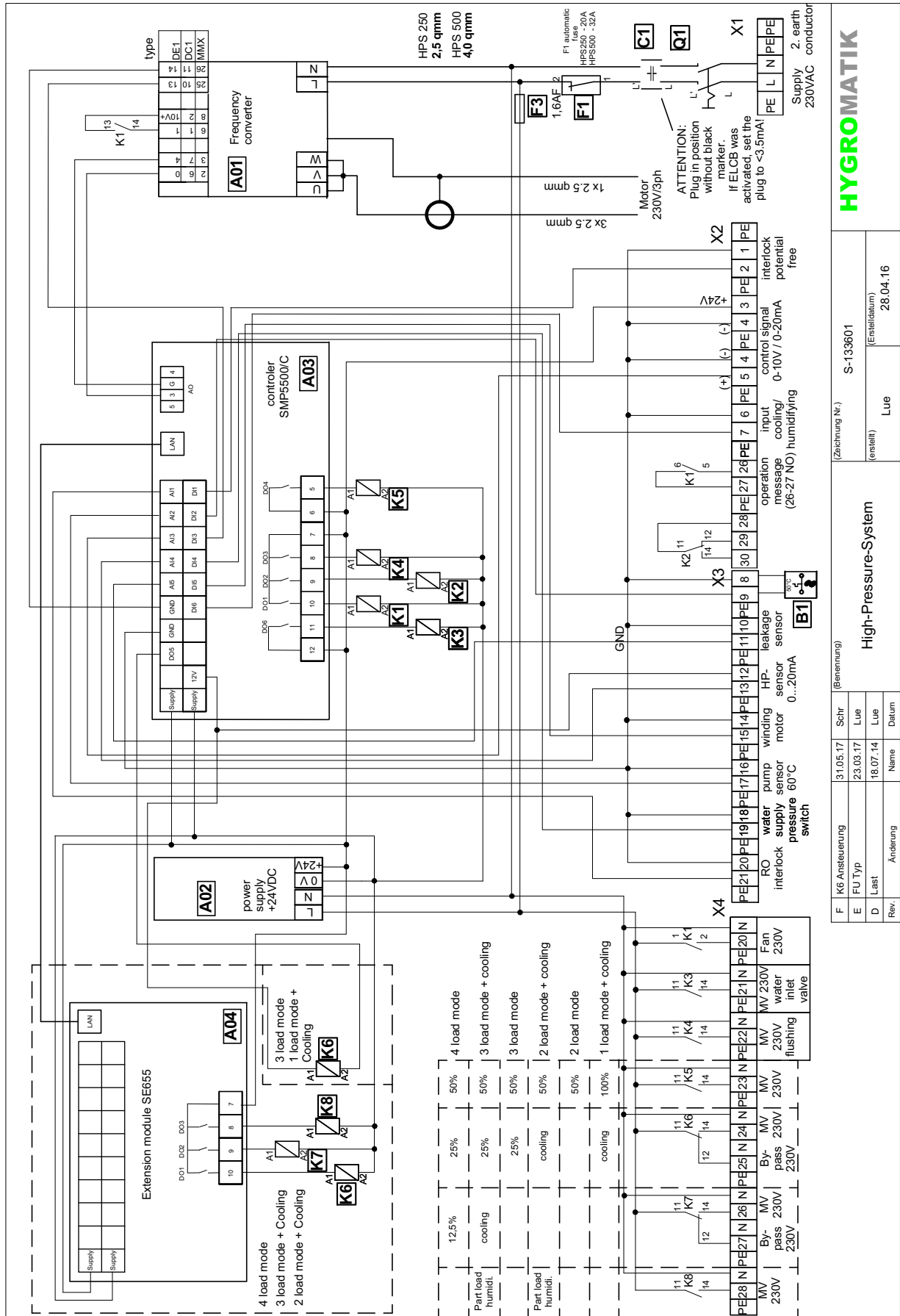

HYGROMATIK		S-133601	
High-Pressure-System		(Erstelldatum) 28.04.16	
(Benennung)		Lue	
(Zzeichnung Nr.)		(erstellt)	
F K6 Ansteuerung	31.05.17	Schr	
E FU Typ	23.03.17	Lue	
D Last	18.07.14	Lue	
Rev.	Änderung	Name	Datum

11.4 Inspecting the electrical installation

The electrical installation must be checked by an electrician in accordance with customer requirements and the regulations set out by the public electricity supply company:

- Does the mains voltage match the voltage specified on the nameplate / delivery note?
- Have all electrical connections been carried out according to the connection diagrams?
- Have all electrical screw and plug cable connectors been attached properly?
- Are the switch-off conditions for protection in case of faults complied with?
- Has the system been earthed?

The system can then be switched on.

12. Commissioning



Caution: The commissioning of a HygroMatik high-pressure nozzle system HPS may only be performed by HygroMatik or an approved installer.

The notification of readiness for the commissioning can be found below. Please send the filled-ready message to said email address or to the fax number given.



Company:

AIRTREND Limited

Address:

Predstavništvo u Beogradu
Kumanovska 14, 11000 Beograd

Contact partner :

Tel: 011 383 68 86, 308 57 40

Date :

Faks: 011 344 41 13

e-mail: gobrid@eunet.rs

web: www.airtrend.rs

Notification of readiness for commissioning a HPS Systems

Unit: HPS-

Order.-No.: AB

Plant designation / Location:

Dear Sirs,

For commissioning the following sanitary / electrical connections must be supplied and in function:

- On-site power supply (230V, 50 Hz)
- Water supply (reverse osmosis water) with line pressure 2 – 5 bar
- Control signal 0-10 V and safety chain
- Sewage connection DN40
- Mounting rails are installed according to instructions
- Vortex module wall and droplet separators are inserted in the mounting rails
- Fan, heat exchanger and control for a test run of the entire system
- Hose guides M32 for high pressure hoses through the device chamber

We need about 4 hours for the commissioning of one unit. During this time, the system will be switched on and off for several times, and control signals should be allowed to be set manually. The presence of an on-site control engineer is therefore imperative. Please send us the notification of readiness preferably **10 working days** before the desired date.

Best regards

Your HygroMatik Service Team

We confirm that the above connections are fully ready.

Desired date for commissioning: _____

If the commissioning cannot be performed due to on-site reasons such as lack of water, or power supply, the resulting travel costs and time will be charged.

Date: _____

Company/Signature: _____

13. Device Control

13.1 Electrical and electronical components of the device

In the system housing, below the fold-up console cover, the electrical components are arranged along with the terminals. A PLC (3) is responsible for control.

In the display and control unit (1) of the control important operating data are displayed and parameter settings can be adjusted.

A frequency inverter (2) delivers different frequencies for the asynchronous motor of the pumping station that is in the lower part of the system housing.

Depending on the pump speed, the water pressure and thus the volume of the water to be sprayed can be varied. The water pressure can have values between 25 and 75 bar.

Below 25 bar, there is no optimal spray pattern of the nozzles. The higher the water pressure, the better the spray pattern and thus humidification.

The main switch (4) on the right hand side serves to switch the HygroMatik nozzle system HPS on and off.

HygroMatik nozzle system HPS

1	Display and control unit
2	Frequency inverter
3	PLC control
4	Main switch

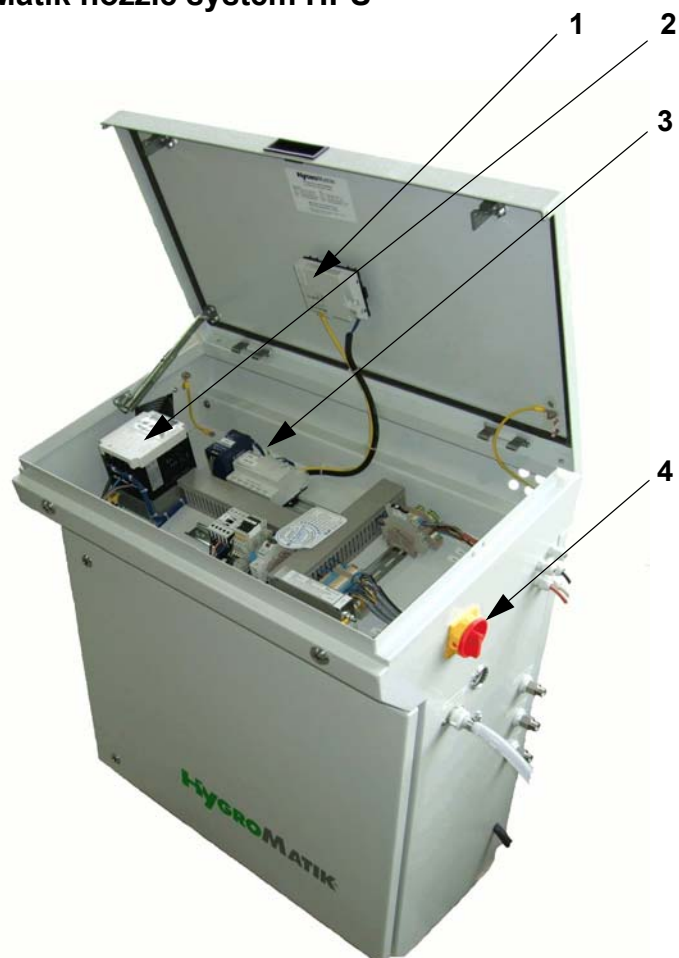

13.2 Control options (modes of operation)

The usability of the modes of operation described below depends on the actually available physical system implementation, i.e. the number of available nozzle sections.

Basic prerequisite for operating the system is the enabling via terminals 1 and 2 by a max.-humidity switch or an on-site disengaged locking mechanism.

Exhaust air cooling

The extract air cooling is activated by a customer-provided potential-free contact across terminals 5 and 6. The extract air cooling does not require a separate control signal and runs in single stage mode only. The purpose of the extract air cooling is to transfer maximum cooling capability into the supply air flow (heat exchanger provided by customer), to support air conditioning systems. In this type of application humidification is typically 95 to 100 percent. All nozzles are immediately supplied with maximum power when the system is enabled. If the humidity switch or another sensor detects that cooling is no longer necessary the enabling is cancelled and the system goes to stand-by mode.

Supply air humidification (standard operation)

This mode requires an on-site control signal of 0-10V (4-20mA) on terminals 4 and 5. All nozzles provided are driven with an atomisation pressure of 25 - 75 bar. The system reaches maximum possible humidification output at 100 percent of the control signal.

Supply air humidification 2 load mode (normal requirements; comfort humidification)

This mode is only available on a system featuring at least 2 nozzle sections.

This mode requires an on-site control signal of 0-10V (4-20mA) on terminals 4 and 5. In the range from 0 to 50 percent of the control signal, only one nozzle section is driven with an atomisation pressure of 25-75 bar, correspondingly. This range is called „partial load range“. If the control signal reaches 55 percent, the pumping station switches on the second nozzle section and reduces the pressure to 25 bar. With the control signal now rising to 100 percent, the output pressure on the nozzles rises proportionally up to 75 bar and the system reaches the maximum possible humidification output.

Supply air humidification 3 load mode (process humidification)

This mode is only available on a system featuring at least 3 nozzle sections.

This mode requires an on-site control signal of 0-10V (4-20mA) on terminals 4 and 5. In the range from 0 to 30 percent of the control signal, only one nozzle section is driven with an atomisation pressure of 25-75 bar. The range is called „the first stage“. If the control signal exceeds approx. 30%, the pumping station switches on the second nozzle section and reduces the pressure to 25 bar. In the control signal range between 30 and 60 percent the nozzle output pressure is proportionally increased up to the maximum of 75 bar. Following this the third nozzle section is switched on as the control signal is increased beyond the 60 percent, while the pressure is decreased to 25 bar again. A further rising control signal leads again to the increase of the nozzle pressure up to the maximum of 75 bar corresponding to a control signal of 100 percent. The system has then reached its maximum humidification output.

Supply air humidification 4 load mode

This mode is only available on a system featuring 4 nozzle sections. In the range from 0 to percent of the control signal, only one nozzle section is driven with an atomization pressure of 25-75bar (first stage). If the control signal exceeds approx. 30 percent, the pumping station switches on the second nozzle section and reduces the pressure to 25 bar.

With a control signal now rising to max. 50 percent, the output pressure on the nozzles rises to 75 bar. When the control signal exceeds approx. 50 percent, the third stage is also switched on and the atomisation pressure is again reduced to 25 bar.

The further increase of the control signal up to max. 70 percent makes the output pressure on the nozzles reach 75 bar. Beyond the 70 percent the third nozzle stage is also switched on and the atomisation pressure is reduced again to 25 bar.

With the control signal now rising up to 100 percent the output pressure on the nozzles rises to 75 bar and the system reaches maximum possible humidification output.

In this mode of operation the system has the best controllability even in the range of minimum output demand.

Zone operation

Up to 3 zones (i.e., humidifying chambers) may be driven by a single pump station with each zone controlled via 2 high pressure valves in combination with a hygostat of its own. By this means the humidifier output may be increased or reduced in 33% steps. The control characteristic of each zone may be individually optimized by the according parameters. This mode of control is denominated as „quasi-continuous“. It allows for much better control accuracy when compared to 1-step zone control.

Combined modes

This control option combines supply air humidification and exhaust air cooling while humidification may run in standard, 2 load and 3 load mode.

13.3 Description of the control functions



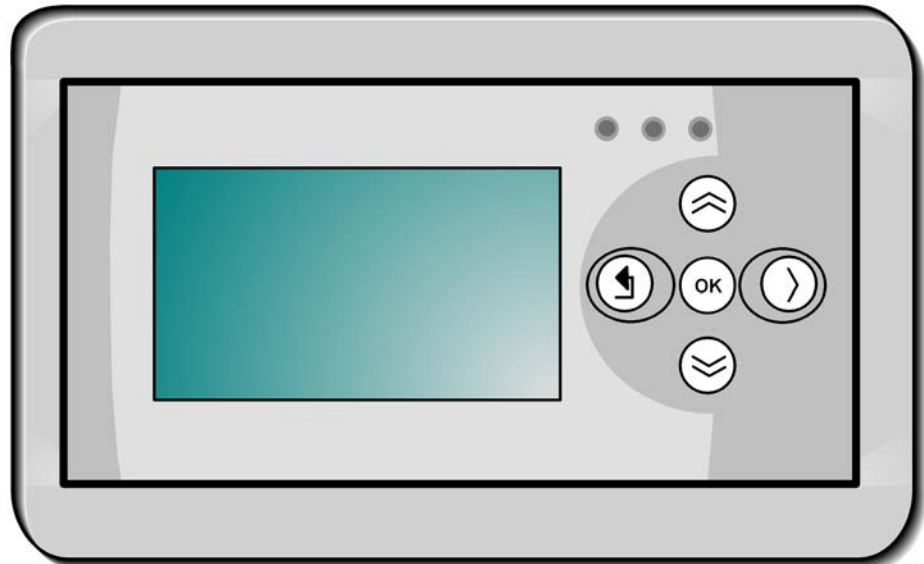

13.3.1 Display and control unit

The display and control unit for monitoring and activating the system functions is built in the cover of the HygroMatik nozzle system HPS.

The display and control unit comprise a display field and 5 function keys for navigation and parameter input.



Description of button functions:

-  - menu navigation backwards / increase value
-  - menu navigation forward / reduce value
-  - confirm entry
-  - menu navigation backwards
- press longer = back to previous menu
-  - menu navigation forward

Display particularities

- Selected input fields show a blinking underscore
- Selected digit positions show a blinking cursor

Status LEDs:

red: flashes in case of malfunction

yellow: lights up as operating indicator for "humidifying" and "cooling" - flashes when "RO delay" is active

green: lights up when there is no fault

13.3.2 Switch on system

- » Switch on the system using the main switch on the side of the housing

When the switching the system on the device control initialises itself. After approx. 15 seconds, the display shows:



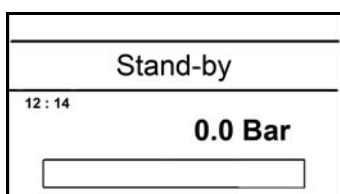

After additional 30 seconds, the display shows:



The current operating state is displayed.

13.3.3 Menu structure

Navigate through the menu structure with the buttons  (menu navigation forward) and  (menu navigation backwards).

Menus are called up with the key .

The main menu includes the two submenus READING VALUES and SETTINGS.

The submenu READING VALUES serves to read out the set operating parameters.

The submenu SETTINGS includes additional submenus in which system and display settings can be changed.

Some of the settings are password (code) - protected . The following code levels are implemented for managing the different access rights.

- Code 0
The options for changing settings are limited. Only date, time and language can be changed.
- Code 010
Changes can be made in the menus PARAMETER and FAULT HISTORY



The code level is automatically reset to „0“ after a certain time of inactivity.

Menu structure overview

1. READING VALUES
2. SETTINGS
 - DATE & TIME
 - LANGUAGE
 - PASSWORD
 - PARAMETER (only available on Code 010 level)
 - FAULT HISTORY (only available on Code 010 level)

13.3.4 Reading values



The operating parameters of the system can be read out in the READING VALUES menu. Using the  or  keys browsing the different readings is possible.



There the following readings exit:

- 1/11 Act. pressure value: current value of the pressure [bar]
- 2/11 Int. control signal [%]
- 3/11 Ext. control signal [%]
- 4/11 Output limitation [%]
- 5/11 Set value r.h. [%] (only on control port PI controller)
- 6/11 Actual value r.h. [%] (only on control port PI controller)
- 7/11 Pump cycle time [h]
- 8/11 Operating hours [h]
- 9/11 Time to maintenance [h]
- 10/11 Time to VDI flush [h,m]
- 11/11 Counter floating

13.3.5 Settings

The menu SETTINGS includes the following submenus:

- DATE & TIME
- LANGUAGE
- PASSWORD
- PARAMETER (only available on Code 010 level)
- FAULT HISTORY (only available on Code 010 level)

Navigation through the menu structure is possible using the keys  or  keys.

For selection of a menu use the  .key.

Menu SETTINGS on Code 0 level:

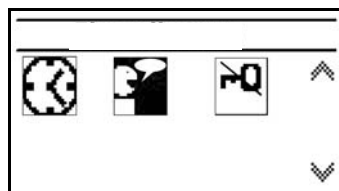

Menu SETTINGS on Code 010 level:

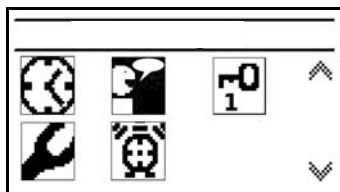

13.3.6 Set time and date

Select DATE AND TIME



- » Position the cursor to the DATE AND TIME icon using the menu navigation keys
- » Confirm the selection with the .key

Set time

The time is displayed in the hr:min:sec format.

- » Using the or keys, select hours, minutes or seconds for setting.
- » Confirm the selection with the .key
- » Select a number with the or .keys
- » Set the number with the keys or .keys
- » Save the entry with the .key

Set day of the week



- » Using the or keys, set the cursor to the item Day of the week
- » Select the day of the week setting with the key
- » Set the day of the week with the and keys
- » Save the entry with the key

Set date

The date has the format day/month/year with 2 digits each.

- » Using the or keys, select day, month or year for setting
- » Confirm the selection with the key
- » Select a number with the or keys
- » Set the number with the and keys
- » Save the entry with the key

Save settings

- » Position the cursor to the UPDATE field using the  or  keys
- » Save the settings with the  key

The display thereafter shows the SETTINGS menu again.
The changes were saved.







Note: If the unit is without power for 48 hours, the set values will be lost.

13.3.7 Set language



- » Position the cursor to the icon LANGUAGE icon using the menu navigation keys
- » Confirm the selection with the  key

The currently set language is displayed.

- » Open the language selection with the  key
- » Set the desired language with the  and  keys
- » Confirm the selection with the  key







The display thereafter shows the start screen in the selected language. However, it might take up to 60 seconds to do so.

13.3.8 Enter password (code)



- » Position the cursor to the PASSWORD icon using the menu navigation keys.
- » Confirm the selection with the  key

The entry field for the password appears.

- » Activate the entry field with the  key
- » Select the required number position with the  or  keys
- » Enter the required number with the  and  buttons
- » Confirm the selection with the key  key

Thereafter, the menu structure reflects the currently set code level access rights.

13.3.9 Parameters (Code 010)





The operating parameters of the system can be set in the PARAMETER menu.





- » Position the cursor to the PARAMETER icon using the

menu navigation keys.

- » Confirm the selection with the key  key

Parameter 1 is displayed.

Select the parameter to be changed with the  or  keys

- » Confirm the selection with the  key
- » Browse through the available pre-defined parameter settings using the  and  keys
- » Select the displayed setting with the  key
- » Pressing the  key for longer period of time quits the PARAMETER menu

The following parameters can be changed:

Designation/function	Selection option
Mode of control	<ul style="list-style-type: none"> • Ext. controller • 1-step • PI - controller Factory setting = Ext. controller
Control signal ¹⁾	<ul style="list-style-type: none"> • 4-20 mA • 0-10V • 0-5V Factory setting = 0-10V
OFF-threshold [%]	5.0 -50.0 Factory setting = 10.0
P-value r.h. ²⁾ [Gain]	50-200 Factory setting = 100
I-value r.h.[s] ²⁾	50-500 Factory setting = 100
Reset maintenance	No/Yes Factory setting = No
Output limitation [%]	25-100 Factory setting = 100
Set value r.h. [%] ²⁾	10-100 Factory setting = 50
Power retention [%]	25 - 100 Factory setting = 100
Delay RO	0 - 60.0s Factory setting =5.0





¹⁾ not available with 1-step control

²⁾ only visible if „Mode of control“ is set to „PI-controller“

13.3.10 Fault history (Code 010)



The FAULT HISTORY menu allows for the reading of the last 8 error messages.

- » Position the cursor to the FAULT HISTORY icon using the menu navigation keys
- » Confirm the selection with the  key
The last error message is displayed.
- » Using the  or  keys browse the last 8 error messages that are in chronological order
- » Pressing the key  key for a longer period of time quits the FAULT HISTORY menu.

13.4 Overview of error messages

Error code	Fault report	Description	Possible cause	Rectification
F1	Water inlet Pressure < 1bar	Water supply insufficient. Inlet pressure must be between 1 and 5 bar	Water supply not connected water filter blocked	Connect water supply with sufficient pressure check water filter and replace, if necessary
F2	Temperature in housing	The temperature sensor in the housing cabinet measures a temperature above 50°C +/-10%	Fan failed Air inlets and outlets clogged	Check fan and replace, if necessary Clean air inlets and outlets
F3	Frequency inverter defective	Frequency inverter reports a malfunction shown in the display of the frequency inverter	Overload on the motor Motor cable short-circuited Error in the frequency inverter electronics Earth fault of output terminals	For fault elimination, please follow the instructions in the documentation of the frequency inverter
F4	Motor winding	Temperature control of the motor winding tripped because of excessive temperature	Forced ventilation failure Inlet opening of forced ventilation blocked	Check forced ventilation and replace, if necessary Remove blockage

Error code	Fault report	Description	Possible cause	Rectification
F5	Low pressure	Pressure cannot be built up within 30 seconds after actuation of the high-pressure pump.	Pressure line leaking Lack of water HP sensor signal cable not connected	Check pressurised water line and replace, if necessary Check and correct cable connections
F6	Over pressure	Pumping pressure of pressurised water exceeds 75 bar for 30 seconds	Nozzles clogged Pressure relief valve not properly set	Clean or replace nozzles Please contact HygroMatik
F7	Sensor error pressure	The pressure sensor value is outside the normal range	Pressure sensor defective Line break	Replace pressure sensor Replace line
F8	Pump temperature	Pump temperature exceeds 60°C	Incorrectly set bypass Ventilation of the housing not existent	Check and set the bypass valve to 9 Hz at 1V control signal Check housing ventilation
F9	Leaking	Water/oil has leaked from the pump and the float switch trips	The pump is leaking	Replace seals or pump, if necessary
F10	Sensor error humidity	The value of a connected humidity sensor (option) is outside the normal range.	Humidity sensor defective Line break	Replace humidity sensor Replace line
F11	Expansion unit	Expansion unit not detected	LAN cable broken Supply voltage missing	Replace cable Check power supply

13.5 Menu set-up and parametrisation

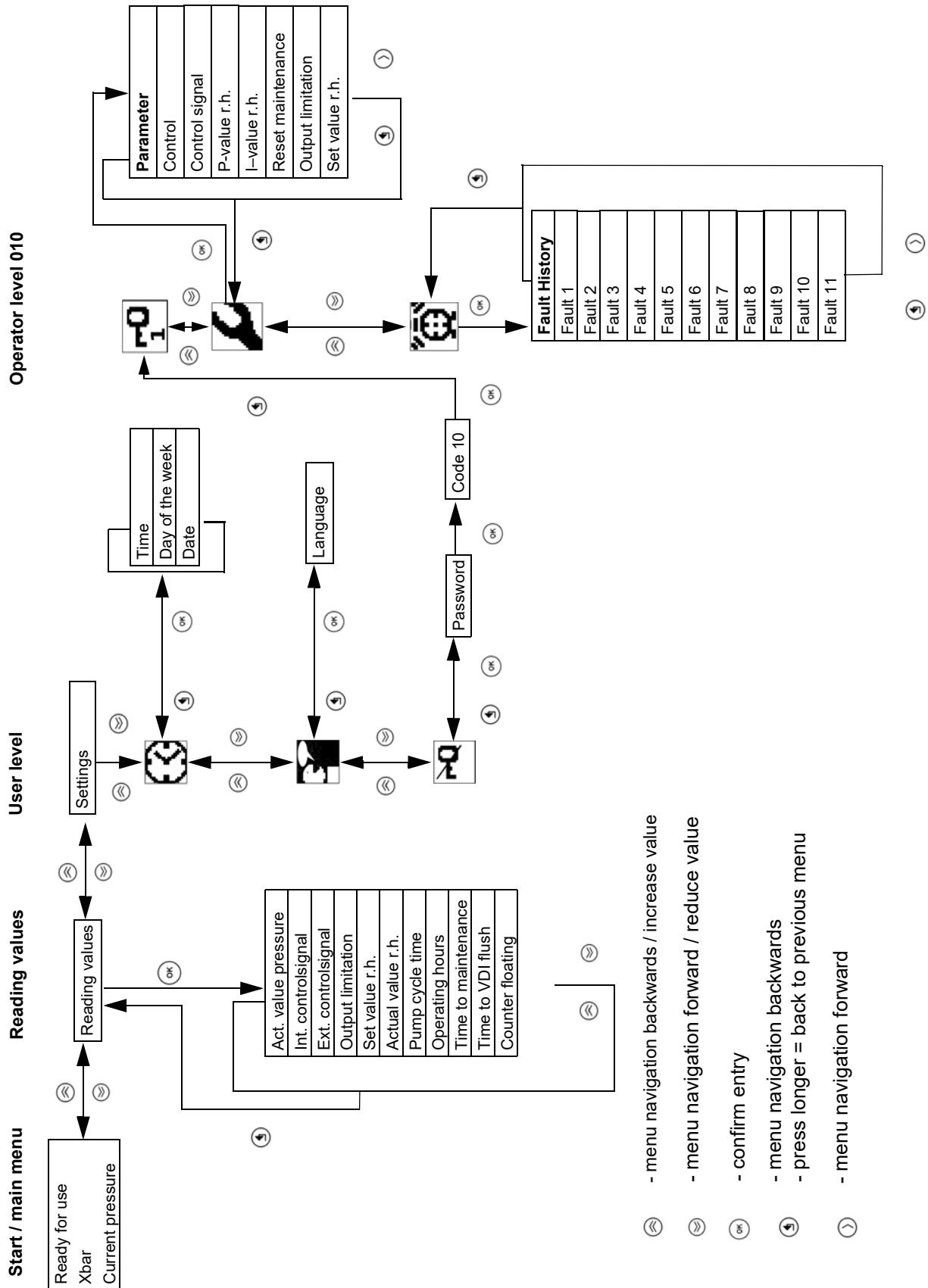

14. Maintenance

The HygroMatik high-pressure nozzle system HPS is maintenance-friendly. However, operational faults which can be traced back to inadequate or improper maintenance may occur.

Regular maintenance of the HygroMatik high-pressure nozzle system HPS is indispensable for ensuring long service life.



Caution: For maintenance work please bear in mind that:

- the system must be serviced by qualified appointed staff only;
- safety instructions must be followed;
- the system must be taken out of operation and secured to prevent it from being switched on before maintenance work is performed; and
- after maintenance work has been completed the device must be inspected by qualified staff to determine whether it is safe to operate.

14.1 Maintenance activities

For the system to operate without any problems the following checks and maintenance tasks must be carried out regularly:

1 x per month:

- » Check water tray and housing for contamination and clean if necessary.
- » Carry out a visual inspection of aerosol separators and clean if necessary.
- » Check the high-pressure pump oil level.
- » Check the water filter cartridge upstream of the pump group for contamination and replace if necessary; flush the mains water system if necessary.
- » Check the resulting spray cone of the nozzles and clean or change nozzles if necessary.

1 x per year (or after 2500 h):

- » Check the nozzles as part of annual maintenance and clean in an ultrasonic bath.
- » Change the high-pressure pump oil.
- » Change sealings and valves of high-pressure pump
- » Replace the water filter cartridge.
- » Carry out a visual inspection of the vortex module wall, the aerosol separators and the humidification chamber; clean if necessary.
- » Check the function of the switch-off devices.



Note: If the system has been out of operation for more than three months, maintenance including cleaning of the spray system as well as an oil and O-ring change on the high-pressure pump must be carried out.



Note: The longer the duration of the running time of the pump the quicker the sealings will wear. In such a case please contact HygroMatik.

14.1.1 Changing the oil in the high-pressure pump

An oil change on the high-pressure pump must be carried out once a year (or every 2500 operating hours). If contamination is visible through the oil sight glass the oil may have to be changed more frequently.

Changing the oil:

1. Switch off the HygroMatik high-pressure nozzle system by setting the main switch on the control cabinet to position '0'.
2. Unscrew the oil dipstick (see no. 12).

12



14

3. Loosen the drain screw (no. 14.) and let the oil drain. Be careful of the sealing ring.
4. Tighten the drain screw (no. 14) with the sealing ring in place.
5. Add 15W40 motor oil (approx. 0.4 l) via the filler hole (no. 12).
6. Check the oil level using the dipstick and close the filler hole.
7. Set the main switch to 'I'.



Note: Only use **mineral oil!**

14.1.2 Checking/replacing the mains water filter

The mains water filter must be checked monthly for contamination and replaced if necessary. Colouring of the originally white water filter cartridge indicates contamination.

Contamination results in an increased resistance to flow. This lowers the supply pressure to the pump. An excessively low supply pressure can lead to switch-off of the high-pressure nozzle system HPS (dry run protection).

Replacing the water filter:

1. Mount of water filter housing
2. Filter cartridge (int.)
3. Water filter housing

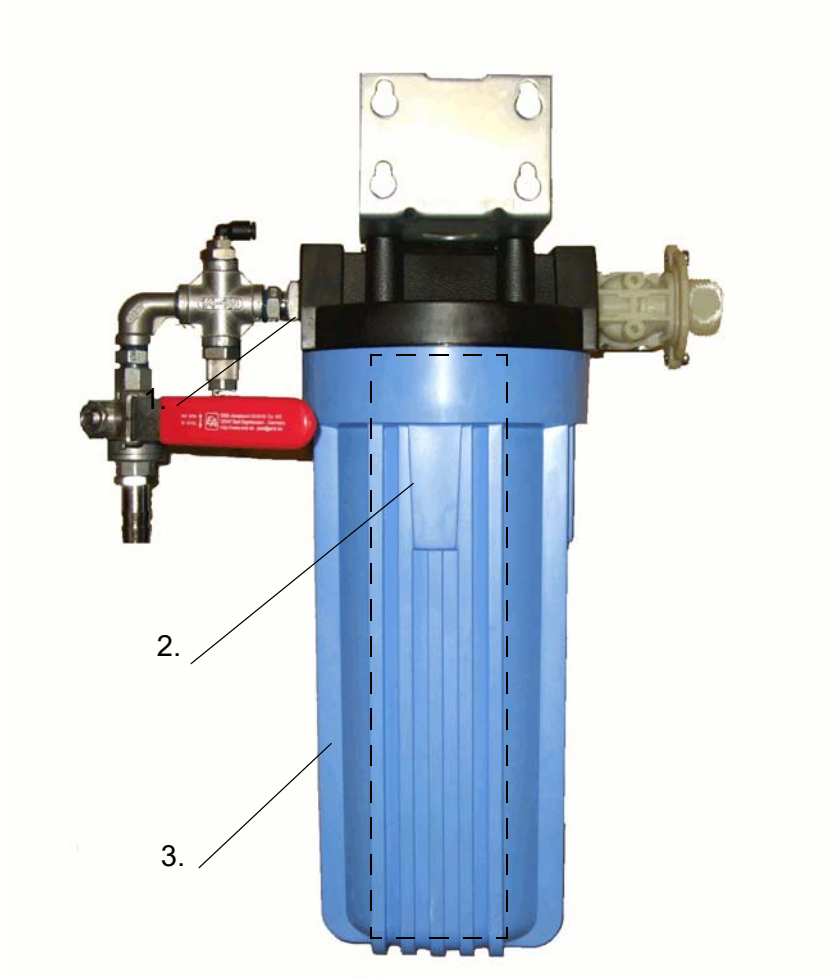

1. Set the main switch on the control panel of the HygroMatik high-pressure nozzle system HPS to '0'.
2. Close the (external) stopcock.
3. Relieve the line pressure.
4. Open the filter housing by hand. The threads may be damaged if pliers are used.
5. Clean the filter housing.
6. Replace the filter cartridge (if necessary).
7. Screw the filter housing into the seat by hand.



Note: Do not pinch the sealing ring.

8. Open the external stopcock.
9. Set the main switch to 'I'.

14.1.3 Flushing the mains water system

1. Set the main switch on the control panel of the HygroMatik high-pressure nozzle system to '0'.
2. Close the external stopcock.
3. Remove the connector for the fresh water supply to the pump group.
4. Open the fresh water valve and flush the water line until the water appears to be free of contamination.
5. Close the fresh water valve.
6. Reconnect the fresh water supply to the pump group.
7. Open the external stopcock
8. Set the main switch back to 'I'.

14.1.4 Cleaning the high-pressure nozzle

1. Set the main switch on the control panel of the HygroMatik high-pressure nozzle system to '0'.
2. Unscrew the nozzle from the holder.
3. Unscrew the nozzle by screwing the inside parts out.



4. Clean the nozzle components in an ultrasonic bath for about 10 minutes, if necessary use a lime remover in low concentration (less than 10%).
5. Put nozzle components back together.



Caution: Risk of injury.

6. Screw the nozzle back on.
7. Set the main switch back to 'I'.
8. Finally: check the spray pattern.



Caution: Ensure that the high pressure is reduced by, for example, activating the flushing program.



Caution: Wear safety goggles when cleaning the high-pressure nozzle.



Caution: Use proper tools to screw on or unscrew nozzles. Even slight mechanical modifications to the impact pin lead to an asymmetric spray pattern.

14.1.5 Cleaning the aerosol separators

The aerosol separators should be checked every 4 weeks for possible contamination and cleaned if necessary. The aerosol separators should be thoroughly cleaned at least once a year.



Cleaning the aerosol separators:

1. Pull or lift the aerosol separators out of the guide rails.
2. Clean the aerosol separators with a cleaning agent and then rinse and dry them.
3. Carry out a visual inspection of the aerosol separators, repeat the cleaning step if necessary and replace the aerosol separators if damaged.
4. Place the aerosol separators back on the guide rails. While doing so ensure that the trap frame drain holes are facing downwards to guarantee free drainage.

14.1.6 Cleaning the vortex module wall

The vortex module wall should be checked for contamination and damage as part of annual maintenance. Any contaminants must be removed with a cleaning agent.



14.1.7 Cleaning the mounting profiles

The mounting profiles of the vortex module wall and the aerosol separators should be reviewed as a part of the annual maintenance for contamination or damage. Possible impurities must be removed with a cleaning agent.

14.1.8 Cleaning the humidification chamber

Clean the humidification chamber and the base tray as required with a cleaning agent, then rinse and dry them.

For cleaning and disinfection we recommend INCIDUR produced by Ecolab.

When using other cleaning and disinfection agents please check material compatibility with all plastic materials used in the humidification chamber.



Caution: Do not aim the water jet at the aerosol separators. Any upstream or downstream heating or cooling units must not become wet during cleaning.

14.2 Extended HPS Service Manual

14.2.1 Replacing the shaft sealing ring of the high-pressure pump EH2009

To remedy any oil leakages on the shaft output side of the pump, the shaft sealing ring must be replaced. The following preparatory measures are required: the water supply must be turned off, the system must be switched off at the main switch, the oil of the high-pressure pump must be drained off and correctly disposed off.

Dismantle the water connection lines of the pump and remove the 4 fixing bolts (pos.1).

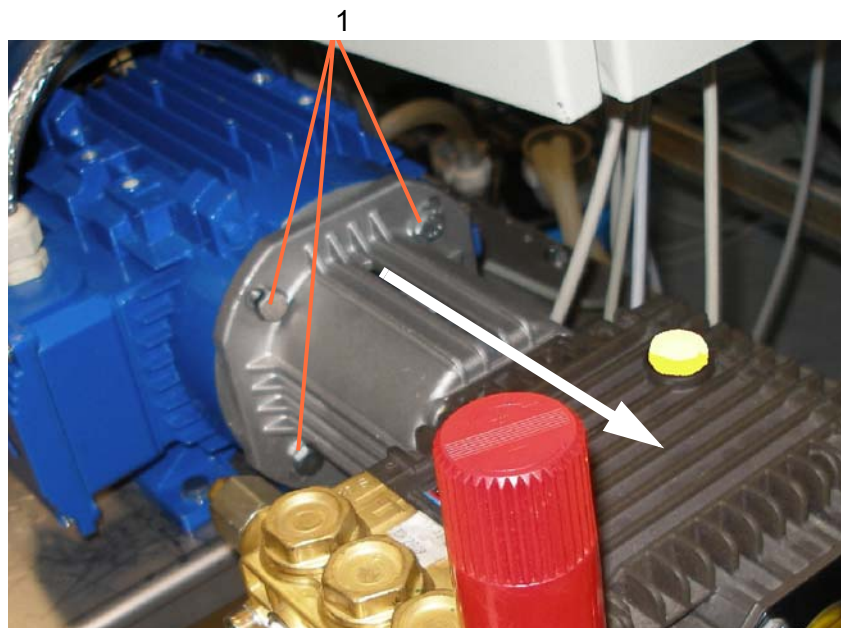

Now disconnect the pump from the motor and place on a suitable work surface.

Dismantle the coupling piece (pos.2) from the shaft (pos.3). To do this, rotate the shaft until the laterally attached securing bolt (pos.4) is visible through the slot of the bell-shaped top and loosen the screw. Then pull the coupling piece off the shaft.

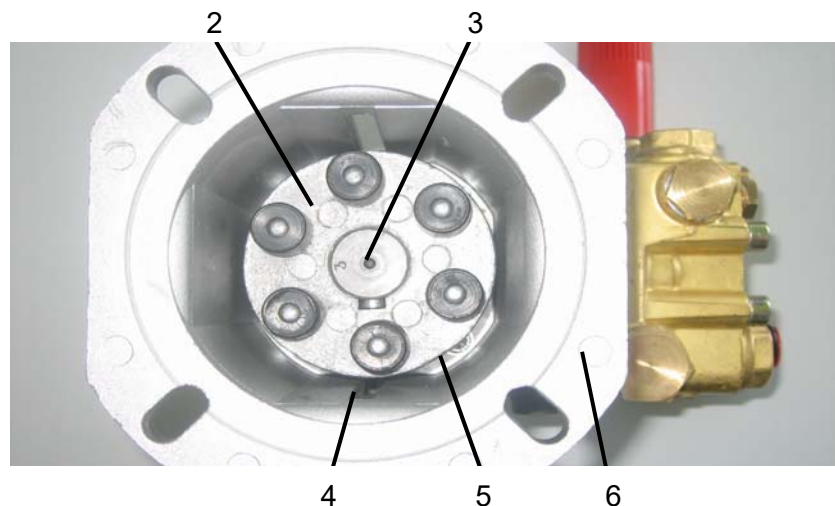

Loosen the 4 bolts (pos.5) that hold the coupling bell housing (pos.6) and remove the bell-shaped top. Now remove the key (pos.7) and lever the shaft sealing ring (pos.8) out of its seating with a suitable tool.



Note: When removing the shaft sealing ring, take care not to damage the seat and the shaft!

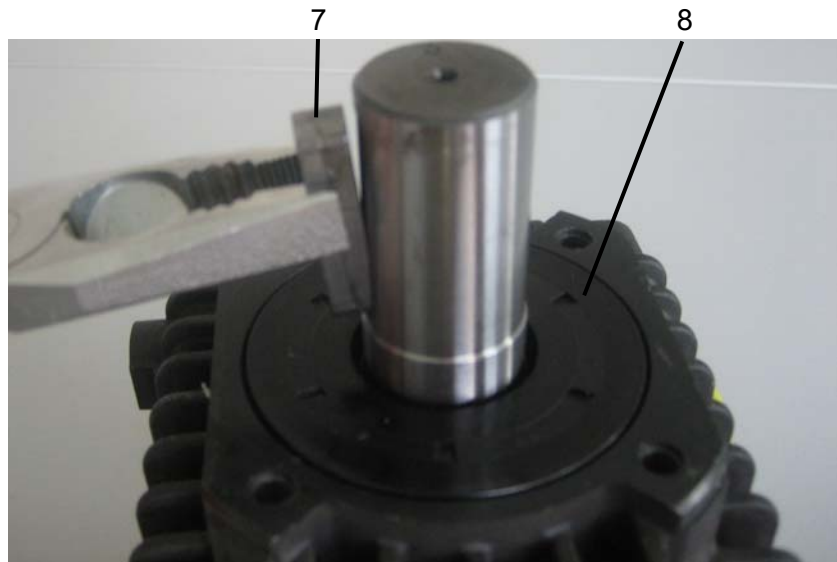

After removing the shaft sealing ring, carefully remove any residues of material left by the sealing ring from the shaft. Do not use any hard implements when doing this in order to avoid causing any damage to the shaft.

Assembly is carried out in reverse order where the new sealing ring is positioned on the shaft by rotating movements and pressing it evenly into place in its seat.

After assembly, the oil outlet (pos.9) must be closed again (pay attention to the sealing ring) and fill the pump with suitable **mineral oil** of the specification **15W-40** (pos.10) until the sight glass (pos.11) is a max. of 3/4 full (filling capacity approx. 0.4l).

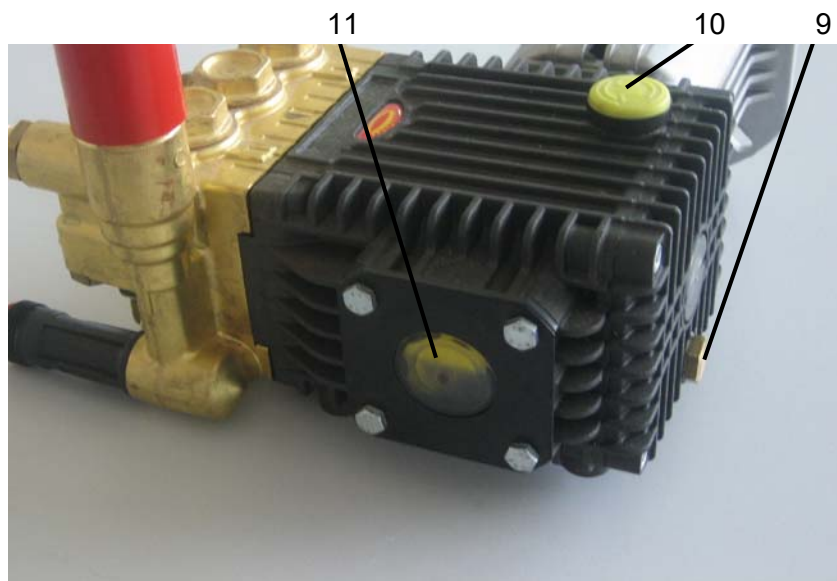

14.2.2 Replacing the valves

HygroMatik uses two high-pressure pumps that differ only in size for the high-pressure jet systems. The construction is generally the same. They each have 3 identical valves on the low-pressure and high-pressure side. If the pump can no longer build up the required pressure, worn valves may be the cause. To replace the valves, the water supply must be turned off and the system switched off at the main switch. To replace the valves, *Replacement kit KIT123* is required for the pump EH2009 which includes 6 valves and 6 O-rings.



12

Disassemble the valve holder (pos.12) with a suitable tool and then detach from the valves (pos.13). Also remove the O-ring (pos.14) in the valve seat of the pump with a small screwdriver or similar.

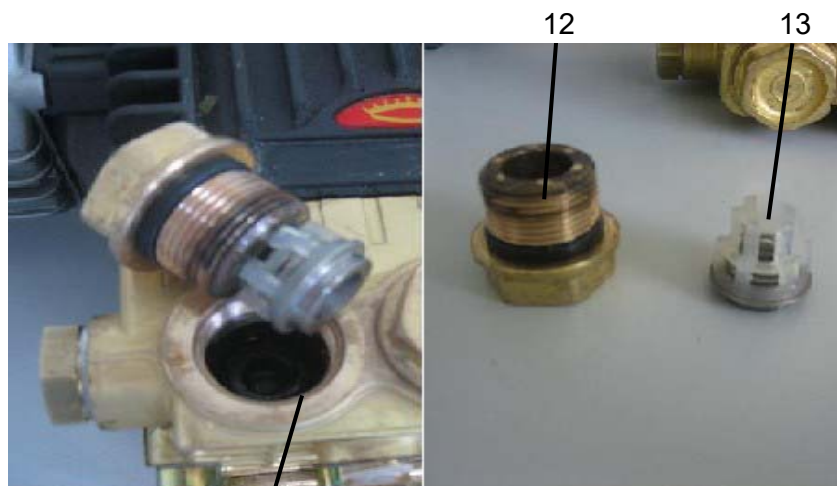

14

In order to reassemble, lay the new O-ring (Pos.14) in the valve seat, put the valve into the holder and screw the holder with the valve into the pump.

14.2.3 Replacing the seals on the water side

If water leaks occur on the pumps, the seals must be replaced. In order to do this, the water supply must be turned off, the system must be switched off at the main switch and the water connection hoses must be dismantled from the pump.

The 8 bolts (pos.15) must be undone. Now the valve block can be detached from the headstock.

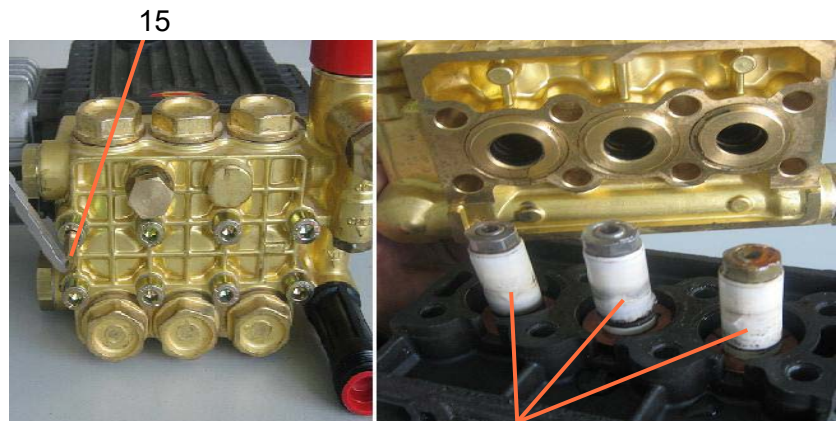

16

Carefully free the ceramic plungers (pos.16) of seal deposits with the included polishing wool, check them for signs of wear and replace if necessary.

Remove all sealing parts (pos.17) and replace by means of *KIT160* or *KIT166* in the pumps.



Note: *KIT160* contains all the seals required for replacing the plunger sealing of a pump. In the event that the metal parts of the sealing are also defective, *KIT166* must be used, of which 3 pieces are required for each pump.

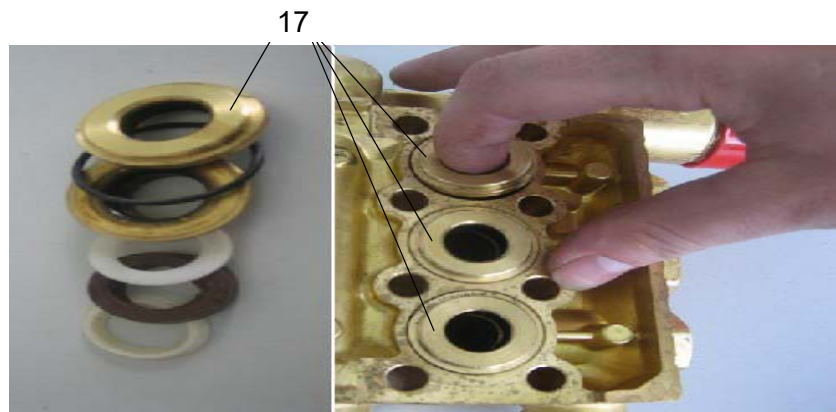

Assembly is carried out in reverse order. To insert the seals suitable tools have to be used.

15. EC declaration of conformity



EG-Konformitätserklärung EC Declaration of Conformity

Hersteller / Manufacturer: HygroMatik GmbH
Anschrift / Address: Lise-Meitner-Straße 3, D-24558 Henstedt-Ulzburg, Germany
Produktbezeichnung / Product description:
High Pressure System: HPS250, HPS500
In den Ausführungen / Type: 1-4 Lasten proportional, 1-3 Lasten proportional und Kühlung
1-4 loads proportional control, 1-3 loads proportional control and cooling

Die bezeichneten Produkte stimmen in der von uns in Verkehr gebrachten Ausführung mit den Vorschriften folgender Europäischer Richtlinien überein:

The products described above in the form as delivered are in conformity with the provisions of the following European Directives:

- 2004/108/EG** Richtlinie des Rates zur Angleichung der Rechtsvorschriften der Mitgliedstaaten über die elektromagnetische Verträglichkeit.
Council Directive on the approximation of the laws of the Member States related to electromagnetic compatibility.
- 2006/95/EG** Richtlinie des Rates zur Angleichung der Rechtsvorschriften der Mitgliedstaaten betreffend elektrische Betriebsmittel zur Verwendung innerhalb bestimmter Spannungsgrenzen.
Council Directive on the approximation of the laws of the Member States related to electrical equipment designed for use within certain voltage limits.

Die Konformität mit den Richtlinien wird nachgewiesen durch die Einhaltung folgender Normen:
Conformity to the Directives is assured through the application of the following standards:

Referenznummer:	Ausgabedatum:	Referenznummer:	Ausgabedatum:
<i>Reference Number:</i>	<i>Edition:</i>	<i>Reference Number:</i>	<i>Edition:</i>
DIN EN 61000-6-2	2006-03	DIN EN 60204-1	1998-11
DIN EN 61000-6-3	2011-09		

Die Anforderungen des Produktsicherheitsgesetzes ProdSG §3 Abs. 1 bis 2 werden eingehalten.
 Eine vom Lieferzustand abweichende Veränderung des Gerätes führt zum Verlust der Konformität.
*The requirements of the German Product Safety Law (ProdSG) paragraph 3 clause 1 to 2 are met.
 Product modifications after delivery may result in a loss of conformity.*

Henstedt-Ulzburg, den / the 19.08.2014

HygroMatik GmbH

Dirc Menssing
Geschäftsführer / General Manager

Dr. Andreas Bock
Technischer Leiter / Head of Engineering

Diese Erklärung bescheinigt die Übereinstimmung mit den genannten Richtlinien, ist jedoch keine Zusicherung von Eigenschaften. Die Sicherheitshinweise der mitgelieferten Produktdokumentation sind zu beachten.
*This declaration certifies the conformity to the specified directives but contains no assurance of properties.
 The safety documentation accompanying the product shall be considered in detail.*

HygroMatik GmbH
Postfach 12 19 . 24549 Henstedt-Ulzburg
Lise-Meitner-Str. 3 . 24558 Henstedt-Ulzburg
Germany

T +49 4193 895 - 0
F +49 4193 895 - 33
hy@hygromatik.de
www.hygromatik.com

Geschäftsführung:
Dirc Menssing
Malke Nielsen
Nicholas J. Anderson

AG Kiel HR B 1282 No
USt-ID-Nr. DE 134846785
Ein Unternehmen der
spirax
sarco Gruppe

Deutsche Bank
Kto. 6256689 00 . . BLZ 200 700 00
IBAN DE12 2007 0000 0625 6689 00
BIC DEUTDE33

17. Spare parts

HPS250	HPS500	Article-No.	Pump Station
x		E-7703020	Motor, 1.1 KW 230/400V-50 Hz ; 1400 rpm
	x	E-7703040	Motor, 2.2 KW 230/400V-50 Hz ; 1400 rpm
x		B-7773151	Pump, highpressure EH 2009 incl. automatic press.contr., clutch, covering
	x	B-7773155	Pump, highpressure EH 1416 incl. automatic press.contr., clutch, covering
x		E-7703100	Pump, highpressure EH2009 without adapting devices drive left sided adaption press.contr. left sided
	x	E-7703110	Pump, highpressure EH1416 without adapting devices drive left sided adaption press.contr. left sided
x		E-7703150	Flange bowl for EH 2009 housing-connect. pump to motor
	x	E-7703152	Flange bowl for EH 1416 housing-connect. pump to motor
x		E-7703170	Coupling for EH 2009 drive-axis motor to pump
	x	E-7703172	Coupling for EH 1416 drive-axis motor to pump
		B-7773171	Unloader valve, autom. EH2009 &EH1416 high press.pump contains HP- & LP-adaption max. 200 bar, max. 50 l/min
		B-7774301	Float switch
		E-7702010	Mounting hook: level control
		E-7774312	Water pan
		E-7706060	Hose, high pressure, DN 8 mm length 0,7 m from pump to highpressure valves
		E-7600184	Hose type PA, black, 10x8 (Piece goods)
		E-7702200	Protection grill, cabinet fan HDS, incl. filter inlay 120 x 120 mm
		E-7621028	Filter element 10" filter quality 10 µm for water-prefilter HP-pumpstation
		E-7705200	Water filter housing, 10" bothside connection 3/4" iD blue sump, pressure release button
		E-7705102	Manometer, 0-10 bar, for control unit CU D=40mm, rear connection G1/8"
		E-7704850	Pressure switch, water inlet
		E-7601626	Hose, PA, black, 4x2 for control unit CU (Piece goods)
		E-7701050	Solenoid valve HDS 220 - 240 V, 50 - 60 Hz 3/4"m - 3/4"m waterinlet
		E-7704510	Coil for HiPres-solenoid valve 230V 50-60Hz
		E-7701100	Solenoid valve, highpressure 2-100 bar for HDS-system
		E-7703044	Fan 230V, 150x172x38 mm, 300m³/h
		E-7703046	Fan covering incl. filter
x		E-7704104	Frequency converter 1.5kW 230V/1ph./N - 230V/3ph
	x	E-7704114	Frequency converter 2.2 kW 230V/1ph./N - 230V/3ph
x		E-7704154	Radio interference sup. filter suppression filter ; 1.5kW HPS 230V/1ph./N
	x	E-7704156	Radio interference sup. filter suppression filter ; 2.2kW HPS 230V/1ph./N
		E-7704316	Power supply HDS control 230VAC/24VDC 15W
		E-2507046	Main contactor 20A(AC1) DILM7 for HDS 1100-2200 coil 24V DC rated voltage 690V
		E-2504052	Auxiliary relay 24V DC 1 switching contact
		E-2505206	Safety fuse 1,6A 5x20mm
x		E-7704610	Line safety switch 16A 1-pole , B-characteristics
	x	E-7704630	Line safety switch 32A 1-pole , B-characteristics
		B-7774103	CPU-unit 822 for HPS
		B-7774105	Multifunktion display display & keyboard

HPS250	HPS500	Article-No.	Pump Station
x		E-0605001	Main switch 25 A
	x	E-0605002	Main switch 32 A
		E-7702200	Protection grill, cabinet fan, incl. filter inlay 120 x 120 mm
		E-7704870	Thermal circuit breaker ; NC with automatic reset, switching point at 50°C ± 5K
		E-7704950	Resistor, 1000 Ohm +/- 5%, 0,25 Watt
		E-7705620	Bypass valve for HDS-system 1/4" female - 1/4" female
			Spare parts for Pump
1		E-7621026	Repair kit KIT 123 to consist of 6 valves for highpressure pump EH2009 (pf100/pf250), 1 set per pump
1	1	B-7621003	Repair kit KIT 160 seals (water) highpressure pump EH2009 (pf100/pf250), 1 set per pump
1	1	B-7621001	Repair kit KIT 166 seals and metal parts highpressure pump EH2009 (pf100/pf250), 1 set per pump
1		E-7621032	O-ring 55,56x3,53 for highpressure pump EH2009 sealing pump shaft (oil)
3		E-7621260	shaft seal crankcase for high pressure pump EH2009 18 x 26 x6 mm, 3 parts nessesary
1		E-7621262	Oil dipstick for high pressure pump EH2009
1		E-7621254	Gasket oil sump for high pressure pump EH2009, 101,27 x 2,62 mm
1		E-7621238	O-ring 10,82 x 1,78mm sealing for oil drain for pump EH2009
3		E-7621256	Gasket piston for high pressure pump, 5,28 x 1,78 mm
3		E-7621030	Piston, ceramics for high pressure pump
1		E-7621220	Drive shaft seal for high pressure pump (oil sided), 25x62x10mm
1		E-7621258	Gasket sight glass for high pressure pump EH2009 26,58 x 3,53 mm
		E-7621224	Special oil for high pressure pumps canister contains 1 liter
x	x	E-7704872	Temperature switch, pump
			Vortex-wall
		E-7701000	Vortex module
		B-7771301	Sealing set, complete for distribution pipe incl. sealing cone and nut
		E-7700550	Blind cap for distributor pipe tightening blind cap without nut
		E-7700554	nut of ferrule fitting at blind cap(distributor pipe) without tightening element
		E-7700556	Closing female fitting 3/8" to close end of distrib. tube
		B-7771053	nozzle holder complete
		E-7621020	O-ring for nozzle holder
		E-7601572	O-ring, for nozzle, 10 x 1,5,
		B-7800311	Spraying nozzle HY 0.27/ 120°, incl. O-ring
		B-7800313	Spraying nozzle HY 0.27/ 60°, incl. O-Ring
		E-7621024	Filter for nozzle
		E-7706040	Hose, high pressure, DN 4 mm, length 370 mm
		E-7706042	Hose, high pressure, DN 4 mm, length 440 mm
		E-7706044	Hose, high pressure, DN 4 mm, length 640 mm
		E-7706046	Hose, high pressure, DN 4 mm, length 820 mm
		E-7706048	Hose, high pressure, DN 4 mm, length 960 mm
		E-7706050	Hose, high pressure, DN 4 mm, length 1130 mm
		E-7706052	Hose, high pressure, DN 4 mm, length 1330 mm
		E-7706054	Hose, high pressure, DN 4 mm, length 1750 mm

HPS250	HPS500	Article-No.	Pump Station
			Hose, high pressure, DN 8 mm
		B-7776402	Hose inlet fitting for humidification chamber
		E-7706062	Hose, high pressure, DN 8 mm, length 2 m to connect pump station and nozzle collector pipe
		E-7706064	Hose, high pressure, DN 8 mm, length 2,5 m to connect pump station and nozzle collector pipe
		E-7706066	Hose, high pressure, DN 8 mm, length 4 m to connect pump station and nozzle collector pipe for HDS-systems
		E-7706068	Hose, high pressure, DN 8 mm, length 6 m to connect pump station and nozzle collector pipe
		E-7706070	Hose, high pressure, DN 8 mm, length 8 m to connect pump station and nozzle collector pipe
		E-7706072	Hose, high pressure, DN 8 mm, length 10 m to connect pump station and nozzle collector pipe
		E-7706074	Hose, high pressure, DN 8 mm, length 14 m to connect pump station and nozzle collector pipe

18. Plant scheme

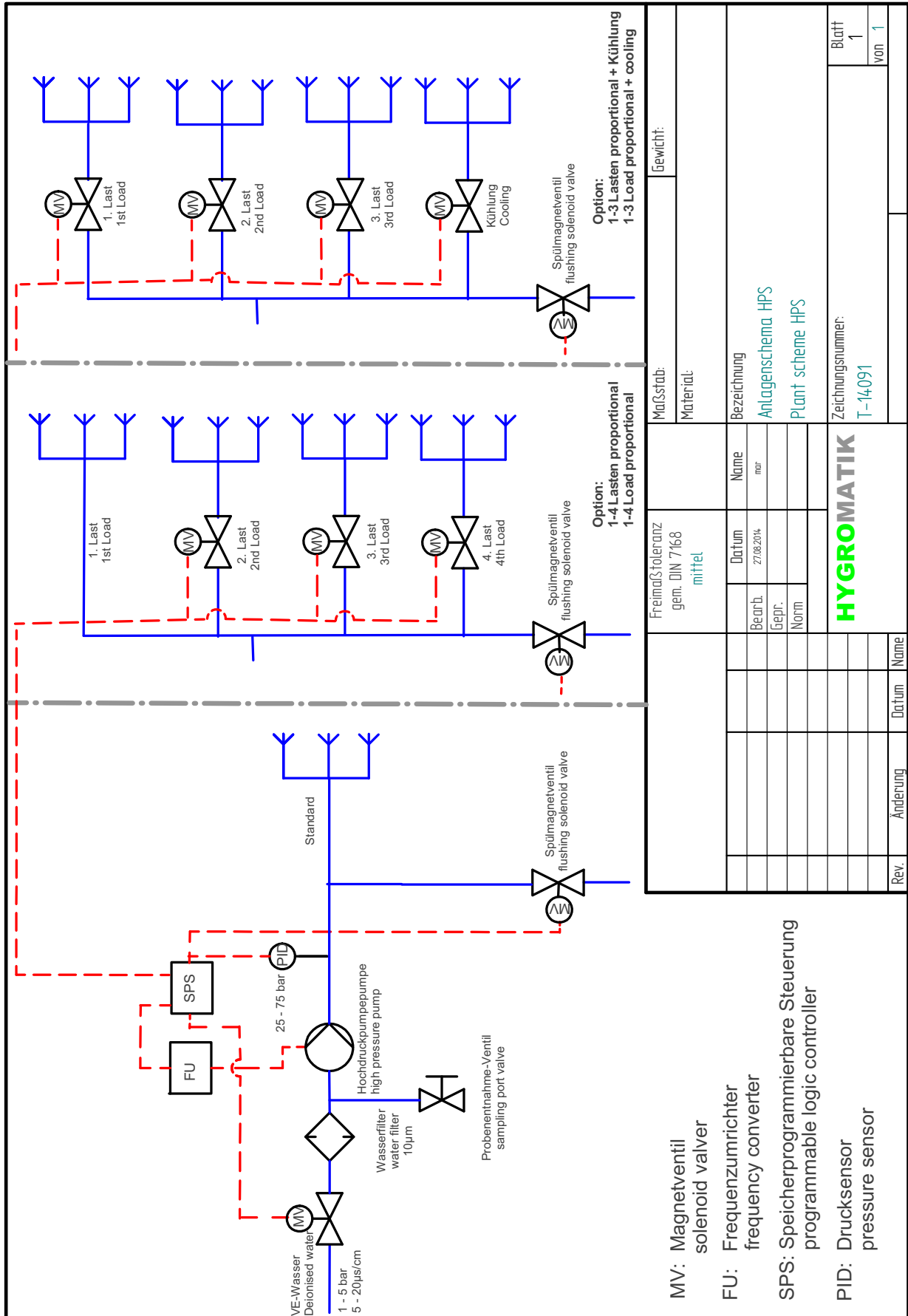

19. Technical data

Pump group	Humidification output* [kg/h]	Rated power [kVA]	Rated current at 75 bar [A]	Max. speed [rpm]	Fuse [A]
HPS250	46 - 250	0.94	4.0	1400	B20
HPS500	90 - 500	1.6	6.7	1400	B32

*: with an efficiency rate of 98%

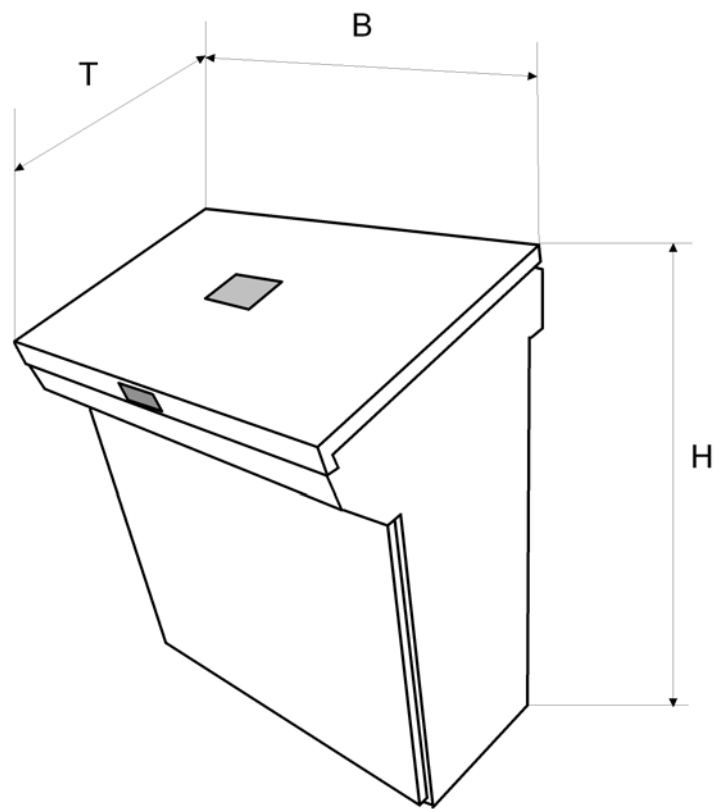

	H	T	B	Weight
HPS250	990	480	850	60 Kg
HPS500	990	480	850	80 Kg



HYGROMATIK[®]

AIRTREND Limited

Predstavništvo u Beogradu

Kumanovska 14, 11000 Beograd

Tel: 011 383 68 86, 308 57 40

Faks: 011 344 41 13

e-mail: gobrid@eunet.rs

web: www.airtrend.rs