

**Electric Heater Steam Humidifier**

HeaterLine



© Copyright HYGROMATIK GmbH; HeaterLine December 2012

Information in this manual is subject to change or alteration without prior notice.

Current version of this manual can be found at: [www.hygromatik.co.uk](http://www.hygromatik.co.uk)



**Warning, Hazardous Voltage:** All work to be performed by trained personnel only. All electrical installation and servicing of the electrical components of this unit to be performed by qualified electricians only. Disconnect power supply before installation and servicing!

<b>1. Introduction</b> .....	<b>5</b>
1.1 Typographic Distinctions .....	5
1.2 Documentation .....	5
1.3 Directions for Use .....	6
<b>2. Safety Notes</b> .....	<b>7</b>
2.1 Overview .....	7
2.2 Guidelines for Safe Operation .....	7
2.3 Disposal after Dismantling .....	8
<b>3. Transport</b> .....	<b>9</b>
3.1 Overview .....	9
3.2 Transport Size and Weigth .....	9
3.3 Packing .....	10
3.4 Interim Storage .....	10
3.5 Check for Complete and Correct Delivery of Goods .....	10
3.6 Included in the Delivery .....	10
<b>4. Operation and Installation</b> .....	<b>11</b>
4.1 Mode of Action .....	11
4.2 Installation and Method of Operation .....	11
4.3 Internal Output Setting .....	13
<b>5. Mechanical Installation</b> .....	<b>14</b>
5.1 Steam Humidifier - environmental conditions .....	14
5.1.1 Fitting Measures .....	15
5.1.2 Equipment Dimensions HL 06-45 .....	16
5.2 Fan Unit (option) .....	17
5.3 Absorption Distance BN .....	19
5.3.1 Determining the Absorption Distance .....	19
5.3.2 Absorption Distance Nomogram .....	21
5.4 Steam Manifold .....	22
5.4.1 Notes on Installation .....	22
5.5 Cover Plate .....	26
5.6 Drill Pattern .....	27
5.6.1 Drill Pattern DN25 (not to scale) .....	27
5.6.2 Drill Pattern DN40 (not to scale) .....	28
5.7 Steam Line .....	29
5.7.1 Types of Installation .....	30
5.8 Condensate Hose .....	32
5.9 Steam Solenoid Valves .....	34
5.10 Chimney-compartment .....	35
5.11 Unit Installation Check .....	35
<b>6. Water Installation</b> .....	<b>36</b>
6.1 Water Quality .....	36
6.2 Water Supply (For Operation with Demineralized Water or Purified Condensate) .....	37
6.3 Water Supply (For Operation with Tap Water or Partially Softened Water) .....	38

---

6.3.1 Feed from Holding Tank .....	39
6.4 Water Treatment .....	39
6.5 Water Discharge .....	40
6.6 Checklist .....	41
<b>7. Electrical Installation .....</b>	<b>42</b>
7.1 Electrical Installation .....	42
7.2 Cable Connections .....	43
7.3 Control Connection .....	43
7.4 Fan Unit .....	44
7.5 Safety Interlock .....	44
7.6 Wiring Diagram .....	45
7.7 Electrical Installation Checklist .....	45
<b>8. Commissioning .....</b>	<b>46</b>
<b>9. Maintenance .....</b>	<b>47</b>
9.1 Maintenance for Operation with Demineralized Water / Condensate .....	48
9.2 Maintenance for Operation with Tap Water or Partially Softened Water .....	49
9.3 Access to Control Unit .....	50
9.4 Cleaning the Coarse Strainer in the Cylinder Base .....	50
9.5 Cleaning Steam Cylinder .....	52
9.6 Cleaning connection hoses, cylinder base and nozzle .....	53
9.7 Replacing Heater Elements .....	53
9.8 Replacing Thermo Sensor (for Heater Element) .....	54
9.8.1 Cleaning of the Control Cylinder .....	55
9.9 Unlocking of a Released Thermo Sensor (for heater element) .....	56
9.10 Unlocking of a Released Thermo Sensor (for Solid State Relay) .....	56
9.11 Unlocking of a Released Thermo Sensor (cylinder cover) .....	56
9.12 Cleaning Blow-Down Pump .....	56
9.13 Removing Inlet Solenoid Valve and Cleaning Fine Mesh Filter .....	58
9.14 Checking Cable Screw Connections, Heater Element Wires .....	59
9.15 Operational Check .....	59
9.16 Dismantling .....	59
<b>10. EC-Declaration of Conformity .....</b>	<b>60</b>
<b>11. Spare Parts .....</b>	<b>61</b>
<b>12. Fax Form - Order for spare parts .....</b>	<b>65</b>
<b>13. Technical Specifications .....</b>	<b>66</b>
<b>14. Exploded View .....</b>	<b>68</b>
<b>15. View of Cabinet .....</b>	<b>69</b>

## 1. Introduction

### Dear Customer,

Thank you for choosing a HygroMatik steam humidifier.

HygroMatik steam humidifiers represent the latest in humidification technology.

They will impress you with their safety, ease of use and economical operation.

In order to operate your HygroMatik steam humidifier safely, properly and efficiently, please read these operating instructions.

Employ your steam humidifier only in sound condition and as directed. Consider potential hazards and safety issues and follow all the recommendations in these instructions.

If you have additional questions, please contact us:

### **Airtrend Ltd.-Gobrid. Ltd.**

Kumanovska 14, 11000 Beograd

Tel. +381 11 383 68 86, 308 57 40

Faks +381 11 344 41 13

E-mail: gobrid@eunet.rs

For all technical questions or spare parts orders, please be prepared to provide unit type and serial number (see name plate on the unit).

### 1.1 Typographic Distinctions

- preceded by a bullet: general specifications.
- » preceded by an arrow: Procedures for servicing or maintenance which should or must be performed in the indicated order.
- ☑ Installation step which must be checked off.
- italics* Terms used with graphics or drawings.

### 1.2 Documentation

#### Retention

Please retain these operating instructions in a secure, always accessible location. If the product is resold, turn the documentation over to the new operator. If the documentation is lost, please contact HygroMatik.

#### Versions in Other Languages

These operating instructions are available in several languages. If interested, please contact HygroMatik or your HygroMatik dealer.

### 1.3 Directions for Use

The proven principle of heating water by the use of electric immersion heaters is exploited to generate steam. Using different tap water qualities or partial softened water (all humidifier types) or fully demineralized water / condensate water (only for humidifier type HeaterLine, HeaterCompact and HeaterSlim).



**Warning:** HygroMatik steam humidifiers emit steam with a temperature of 100° C. The steam may not be inhaled directly.

Only qualified and authorised personnel may operate the unit. Persons transporting or working on the unit, must have read and understood the corresponding parts of the Operation and Maintenance Instruction and especially the chapter 2. „Safety Notes“. Additionally, operating personnel must be informed of any possible dangers. You should place a copy of the Operation and Maintenance Instruction at the unit's operational location (or near the unit).

The steam humidifier is not qualified for exterior application.

## 2. Safety Notes

### 2.1 Overview

These safety notes are required by law. They promote workplace safety and accident prevention.

#### Warnings and Safety Symbols

The safety symbols below identify sections containing warnings about hazards or potential dangers. Please familiarize yourself with these symbols.



**Warning:** Failure to observe this warning may result in serious injury or death and/or damage to the unit.



**Danger, Hazardous Voltage:** Hazardous electrical current! Failure to observe this warning may result in injury or even serious injury or death.



**Warning:** Failure to follow these instructions may result in damage to the unit due to electrostatic discharge. The electronic components of the humidifier control are very sensitive to electrostatic discharges. In order to safeguard these components during installation and servicing, steps must be taken to protect against ESD.



**Reminder:** Materials and consumables must be handled and/or disposed of as required by law.



**Note:** Appears before explanations or cross-references which refer to other sections of the operating instructions.

### 2.2 Guidelines for Safe Operation

#### Overview

Obey all safety notes and warnings present on the unit. In case of a malfunction, switch off the unit immediately and prevent a restart. Repair malfunctions promptly. After any repair work, have qualified personnel check the safe operation of the unit.

Use original spare parts only. Additional national safety regulations also fully apply to the operation of this unit.

This unit is not designed for the use by persons (also children) with limited physical, sensory and mental abilities - or without knowledge and experience. Unless they are supervised or trained by a person, who is responsible for their safety.

Supervise children in order to ensure that they will not play with the unit.

The unit is only allowed to work with connected steam hose that

safely leads the steam.

HygroMatik steam humidifiers are IP20-protected. Make sure that the unit is protected from drips in its installed location.

Installing a humidifier in a room without water discharge requires safety devices to protect against water leakages.

### **Accident Prevention Regulations**



Comply with the Accident Prevention Regulation Electrical Systems and Equipment to prevent injury to yourself and others.

### **Operation of the Unit:**

Do not perform any work which compromises the safety of the unit. Regularly check that all safety and monitoring devices are functioning normally. Do not remove or disable safety devices.

### **Installation, Dismantling, Maintenance and Repair of the Unit:**

Disconnect unit components from power supply prior to maintenance or repair work.

Attaching or installing **additional components** is permitted only with the **written consent** of the manufacturer.

### **Electrical**



Work on the electrical system must be performed by qualified personnel.

Disconnect unit components from power supply prior to work.

It is not allowed to connect the unit to DC voltage supply.

In case of a malfunction in the electrical power supply, switch off the unit immediately. Use only original fuses with the appropriate amperage rating. Regularly check the unit's electrical equipment. Promptly repair any damage, such as loose connections, burned wiring or defective electrical insulation. After proper electrical installation or repair, test all safety mechanisms (such as grounding resistance).

## **2.3 Disposal after Dismantling**



**Note:** The operator is responsible for the disposal of unit components as required by law.



### 3. Transport

#### 3.1 Overview



**Note:** Proceed carefully when transporting the steam humidifier in order to prevent damage from rough or careless loading and unloading.

#### 3.2 Transport Size and Weight

Type*	Height [cm]	depth [cm]	width [cm]	weight [kg]
HL 6	93	42	74	39
HL 9	93	42	74	39
HL 12	93	42	74	40
HL 18	93	42	74	40
HL 24	93	42	74	42
HL 27	93	42	74	42
HL 30	95	48	80	50
HL 36	95	48	80	49
HL 45	95	48	80	50

\* Dimensions and weights can vary insignificantly

The heating element humidifiers type **HeaterLine 60-90** are double units - they consist of two separate units.

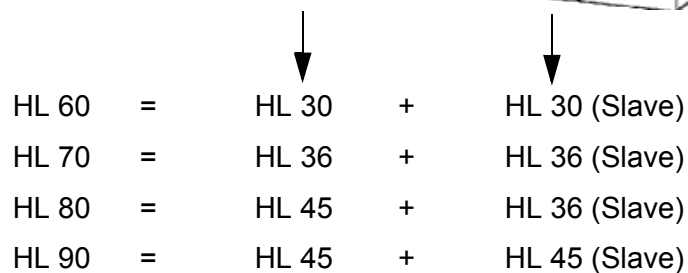
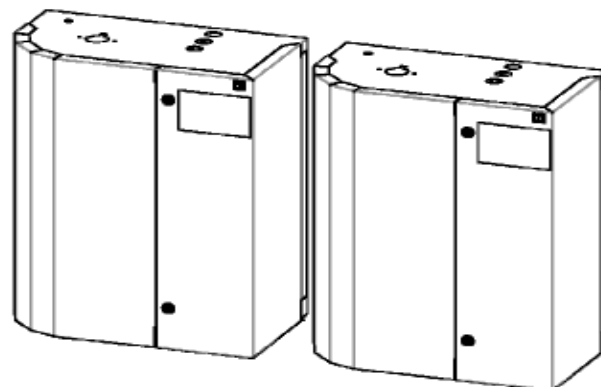

### 3.3 Packing



**Note:** Observe the symbols affixed to the box.

### 3.4 Interim Storage

Keep the unit dry and protect from frost.

### 3.5 Check for Complete and Correct Delivery of Goods

Upon receipt of the unit, make sure that:

- type and serial number on the name plate match what is in the purchasing and delivery documents,
- equipment is complete and in perfect condition.



**Note:** In case of damage during shipment and/or missing parts, immediately file a written claim with your carrier or supplier.

Time limits for filing freight claims with shipping companies are\*:

Transport Company	After Receipt of Goods
Mail	24 hours at the latest
Rail	7 days at the latest
Truck and railway companies	4 days at the latest
Parcel Service	immediatly

\* Subject to change without prior notice.

### 3.6 Included in the Delivery

The delivery includes:

- Unit of the selected humidifier type including selected control.
- Water installation hose.
- Manuals for the steam humidifier and the control.
- Ordered accessories (steam manifold, steam hose, condensate hose, etc.).
- Maintenance o-ring set for steam cylinder.

---

## 4. Operation and Installation

### 4.1 Mode of Action

#### The Immersion Heater Principle

One to five heater elements (8) are placed in a closed cylinder and connected to alternating current. The cylinder (9) is filled with tap water, fully demineralized water or partially softened water. Heat generated by the heater elements increases water temperature to approx. 100°C.

When fully demineralized water is used, the feed water is practically free of minerals. This ensures long life for the cylinder and heater elements since virtually no mineral deposits can settle or build up. Fully demineralized water minimizes the number of service / maintenance checks.

When tap water is used, some of the minerals dissolved in the water will settle in the cylinder as solids of various compositions. Most of these scale deposits are removed by periodic flushing or use of a heavy-duty blow-down pump. See section "Servicing During Operation with Tap Water".

The generated steam has a temperature of about 100°C and minimal positive pressure ("pressureless" steam). It is virtually demineralized and germ-free.

### 4.2 Installation and Method of Operation

By pressing the control switch („Pos. I") the humidifier will be turned on.

When the hygrostat or controller signals a demand for humidification, the inlet solenoid valve (14) opens. The solenoid valve is designed for pressures from  $100 \times 10^3$  to  $100 \times 10^4$  Pascals (1 to 10 bar).

Water is fed into the cylinder (9).

The water level in the cylinder must be maintained within a specified range. If the water level is too high, the elbow acts as a safety overflow for water drainage. If the water level is too low, it could cause the heater elements (8) to overheat. Therefore, power supply to the heater elements is shut off when water levels are too low.

The cylinder water level is controlled by a level control (6). The level control consists of a stainless steel cylinder with two float switches and three reed contacts. The float switches indicate the water level in the steam cylinder: "Dry Run", "Humidification" and "Max. Level". The control capsule is pressure-equalized.

At the standard setting, the inlet solenoid valve (14) opens when the water level remains below “humidification” level for 10 seconds. The water level then rises again to “humidification” level.

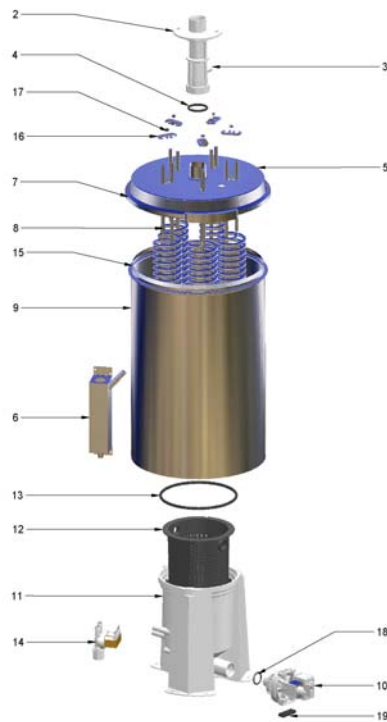

Position	Discription
2	Steam hose adapter
3	Connection control capsule
4	O-ring, steam hose adapter
5	Cover, cylinder
6	Control capsule / Water level control
7	Clamping ring
8	Electrical Heater
9	Cylinder
10	Blow-down pump
11	Base
12	strainer insert
13	O-ring, base
14	Water inlet solenoid valve
15	O-ring, base
16	Pressure plate for heater elements

For more information, also see section “Exploded View.”

The steam cylinder (9) is made of stainless steel. The cover (5) is attached to the steam cylinder using a clamping ring (7). Up to 5 heater elements (8) are mounted on the cover.

The heater elements are equipped with a mechanical high temperature safety. This mechanism provides a redundant safety system in the event of excessively low water levels (“Dry Run”).

The cylinder water is periodically flushed out with a heavy-duty blow-down pump (10). Hygromatik’s SUPER FLUSH system effectively assists this operation. The SUPER FLUSH mechanism generates a strong whirlpool effect in the strainer basket which aids removal of scale deposits during the blow-down process. During this procedure, steam production is interrupted for a few minutes.

Steam is fed into air-conditioning ducts through special steam hoses and steam manifolds. Under normal conditions, this steam has virtually no heating effect on the air to be humidified. Accumulated condensate can be returned to the steam cylinder via a condensate hose.

Direct room humidification (without ducts) is performed using fan units (with blower and nozzle). The steam generator is connected to the fan unit with steam and condensate hoses.

Steam lines in steam bath cabins employ special steam hoses and piping (if required). Accumulated condensate is normally routed into the steam cabin. At a relative humidity of 100%, the supplied steam is used to heat the steam bath.

For maintenance the cylinder can be drained by pressing the control switch „Pos.II”.

### **4.3 Internal Output Setting**

Continuous control of the HeaterLine Type steam humidifier is achieved by proportional control ( pulse-width modulation) of the heater elements. In this way the humidifier can be proportionally operated across the entire output range of 5% - 100% nominal capacity.

## 5. Mechanical Installation



**Warning:** Installation of this unit should be performed by qualified personnel only. Hygromatik accept no liability for damage due to faulty installation.

Obey all safety instructions and warnings on the unit. During installation the unit must be disconnected from its power supply.

Accessory equipment may not be installed on or in the unit without prior written consent from HYGROMATIK. Otherwise the warranty is void.



**Warning:** If the installation of this unit is attempted by only one person there is a risk that the unit will drop down. We propose to carry out the installation by two persons.

### 5.1 Steam Humidifier - environmental conditions



**Note:** When selecting the location for steam humidifier installation, be aware of the following:

- Ambient temperature must be between +5 and +40 °C.
- Relative humidity may not exceed 80% RH.
- Observe clearances specified in the diagrams below to ensure adequate ventilation.
- An Installation in a closed room requires aeration and if necessary temperature conditioning in order to reach the above mentioned environmental conditions.
- HygroMatik humidifiers are not suitable for direct outdoor installation.
- Install the steam humidifier as close as possible to the steam manifold. Use only short lengths of steam and condensate hose to ensure optimal performance.
- Hoses must be laid at a constant 5-10% grade to uniformly prevent sags and kinks.
- The back surface of the steam humidifier heats up during operation (to max. 70°C). Take care that the construction on which the unit is mounted is not made of temperature-sensitive material.
- Place the steam humidifier so that the unit is easily accessible with sufficient space to perform maintenance.
- The unit's protection class is IP20.

## 5.1.1 Fitting Measures

### Wall Distance

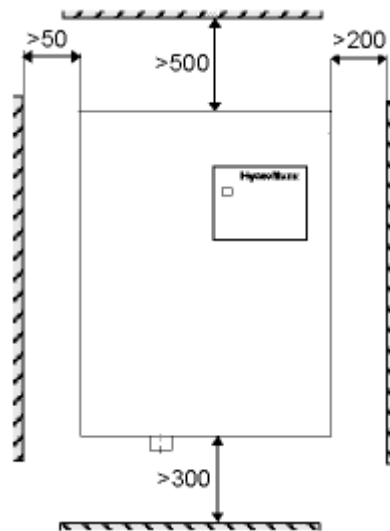

(all dimensions in mm)



**Note:** It is often advantageous to use existing water connections (feed and drain) when selecting the steam humidifier.

### Wall Mounting

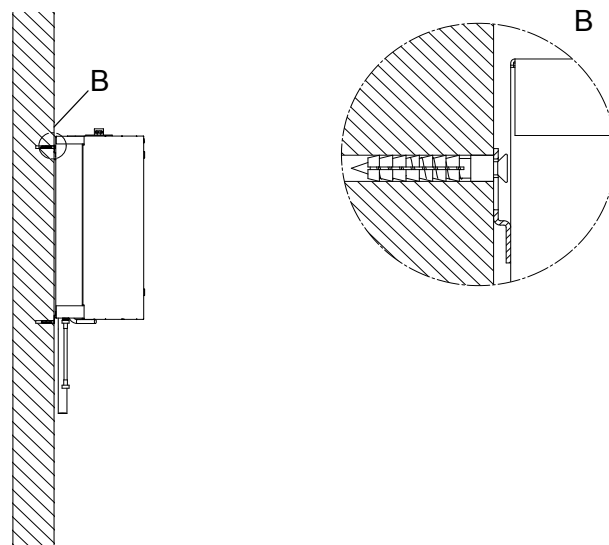

**Note:** To function properly the steam humidifier must be installed vertically.

Measures for drills for wall mounting please see table (measures d and e) in chapter „Equipment Dimensions“. If there is no suitable wall, it is recommended that the equipment is installed on brackets which can be embedded in the floor.

### 5.1.2 Equipment Dimensions HL 06-45

	HL 06-27	HL 30-45
a	831	855
b	644	688
c	322	392
d	591	634
e	771	795
f	38	38
g	268	310
h	51	51
i	40	40
j	167	197
k	161	204
l	76	76
m	41	83
n	56,5	56,5
o	18,5	18,5
all dimensions in mm		

**View from below**

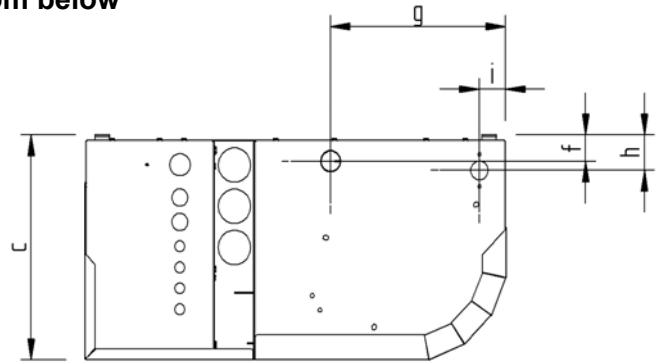

**Rear view**

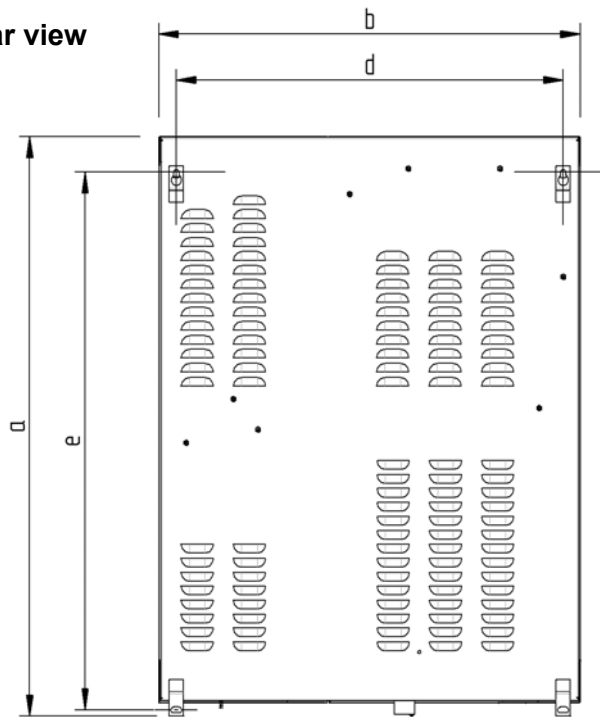

**View from top**

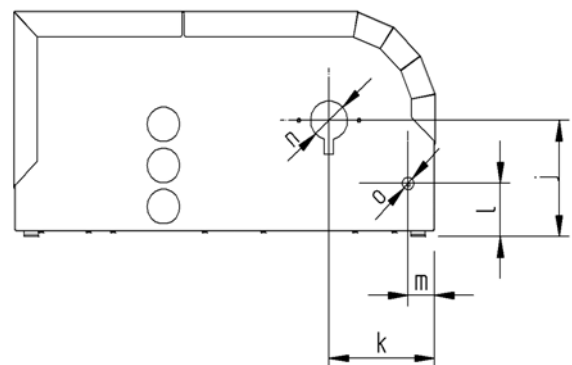



## 5.2 Fan Unit (option)



**Note:** The fan unit should be positioned to avoid drafts. A minimum height of 2 m is generally sufficient.

- Install the fan unit directly on a wall.

Type	Fan Unit
HL 6	VG 08
HL 9	VG 17
HL 18 - 30	VG 30
HL 36, 45, 60	2 x VG 30
HL 70, 80, 90	4 x VG 30

- The fan unit is installed above the steam humidifier.
- When using multiple fan units, do not exceed a maximum distance of 5 m from the steam humidifier.
- Observe the clearances specified in the diagrams below.

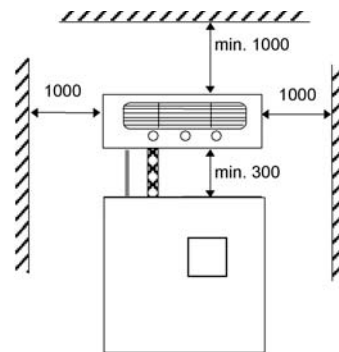

(all dimensions in mm)

Fan unit, wall installation

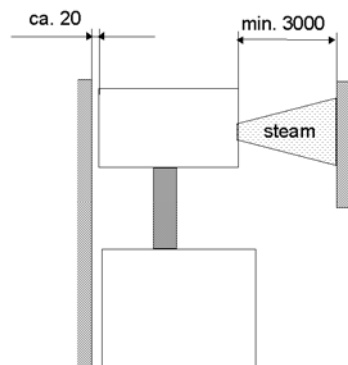

Side view, wall-mounted fan unit

Technical Specifications Fan Unit VG				
Fan Unit		VG08	VG17	VG30
Quantity of Steam	[kg/h]	8	17	30
Steam Inlet	[mmφ]	25	25	40
Condensate Outlet	[mmφ]	12	12	12
Airflow Capacity	[cbm/h]	185	185	350
Nominal Output	[W]	35	35	67
Nominal voltage	[V]	230	230	230
Dimensions				
	W [mm]	441	507	550
	H [mm]	171	171	171
	D [mm]	180	237	277
Weight	[kg]	4,5	6	7
Sound Level (1m distance to the source of noise)	[dB(A)]	50	57	59



**Warning:**

- During operation and a soon afterwards the steam nozzle is hot! If touched this can cause burns to the skin.
- During operation the cross-flow fan rotates. Do not touch the fan during operation.
- During operation hot steam discharges from the nozzle. In the field of the visible steam cloud contact can cause burns to the skin.

### 5.3 Absorption Distance $B_N$

The "absorption distance" ( $B_N$ ) is defined as the distance from the steam feed to where the steam is completely absorbed in the treated air. Inside the absorption distance, steam is visible as mist in the air stream.

Condensation may collect on anything installed inside the absorption distance.

Although steam outside the absorption distance ( $B_N$ ) is completely absorbed, it is not yet evenly diffused in the duct. If you plan to install any parts or devices inside the absorption distance, such as sensors or elbows, we recommend increasing the absorption distance using the formulae below. The absorption distances required for certain installed fittings are distinguished by separate symbols and calculated as a multiplier of the absorption distance  $B_N$ .

Absorption Distance	
$B_N$	for normal obstructions, such as sensors, ventilators, outlets
$B_c = (1,5...2) \times B_N$	for fine filters, heat registers
$B_s = (2,5...3) \times B_N$	for particle filters
$B_d = (2,5...3) \times B_N$	for humidity sensors, duct humidistats

The absorption distance has no fixed value, but depends on many factors. These are depicted in the absorption distance nomogram below.

#### 5.3.1 Determining the Absorption Distance

To determine the absorption distance, the following parameters are required:

- Air humidity before humidification  $x_1$  in g/kg.
- Air temperature after humidification  $t_2$  in °C (with steam humidifiers the change in air temperature due to humidification may be disregarded  $t_1$  or  $t_2$ ).
- Specific increase in humidity  $\Delta x$  in g/kg (can be determined in the h,x diagram)
- quantity of steam introduced  $\overset{o}{m}_D$  in kg/h.
- air speed  $w_L$  in m/s in air duct
- Total length  $l_D$  of the steam manifold installed in the air duct

Length  $l_D$  of the usable steam manifold depends on the dimensions of the air duct. The length of the absorption distance can be reduced by using multiple steam manifolds (also see section on the steam manifold).

**Method:**

Graphically determine absorption distance  $B_N$  using the absorption distance nomogram (also see Section „Absorption Distance Nomogramm“). Enter the value of the parameters enumerated above into the respective quadrants. The resulting point of intersection indicates the value of the desired absorption distance  $B_N$ .

**Notes:**

- Air humidity before humidification  $x_1$ : \_\_\_\_\_ [g/kg]
- Air temperature after humidification  $t_2$ : \_\_\_\_\_ [°C]
- Specific increase in humidity  $\Delta x$ : \_\_\_\_\_ [g/kg]
- quantity of steam introduced  $m_D^o$ : \_\_\_\_\_ [kg/h]
- air speed  $w_L$ : \_\_\_\_\_ [m/s]
- Total length of the steam manifold  $l_D$ : \_\_\_\_\_ [mm]

### 5.3.2 Absorption Distance Nomogram

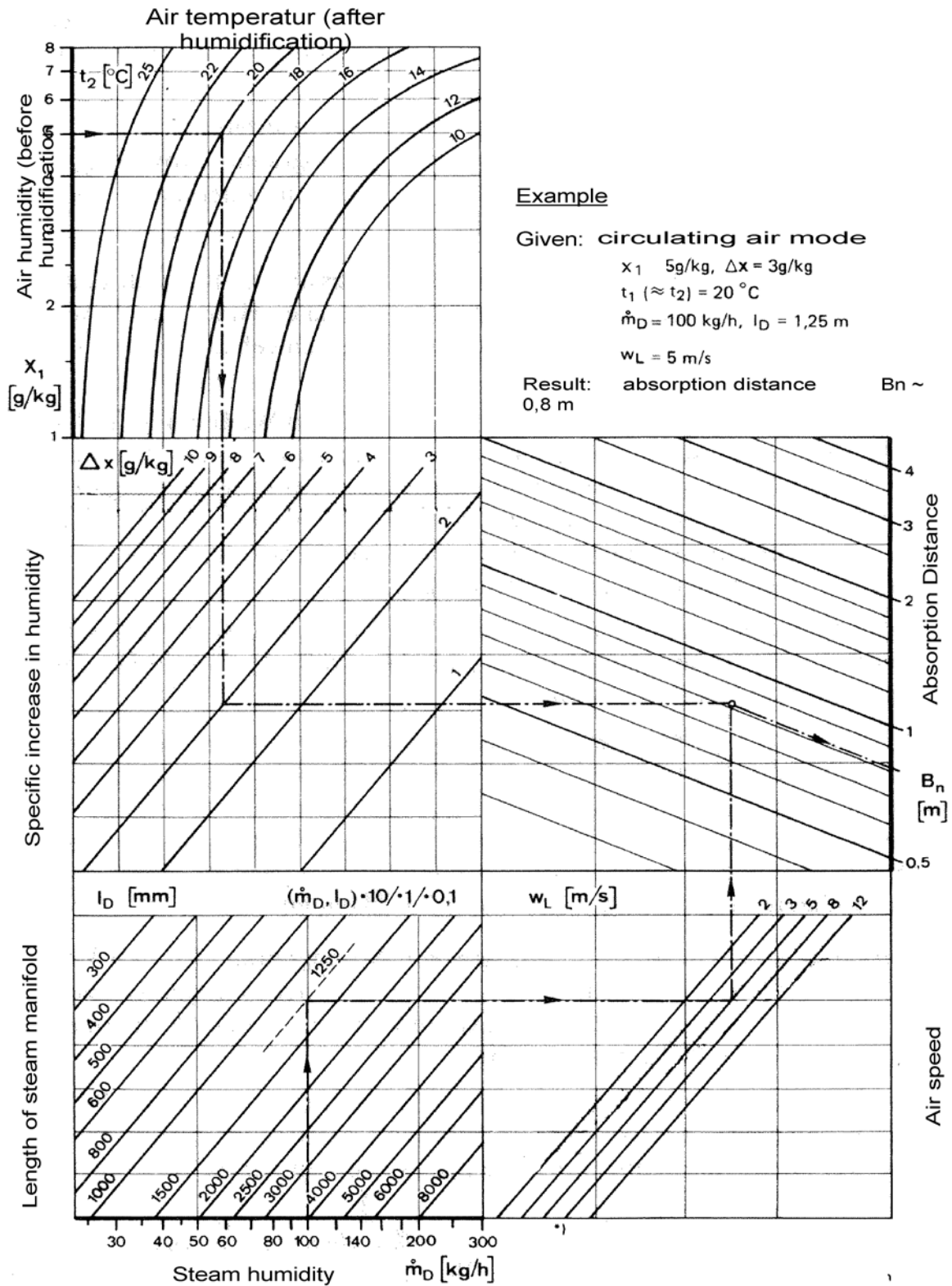

Source: Henne, Erich: Luftbefeuchtung (Air Humidification), 3<sup>rd</sup> Edition 1984 (Page 101), Oldenbourg Industrieverlag, Munich

## 5.4 Steam Manifold

### 5.4.1 Notes on Installation

#### Horizontal installation of steam manifold

These notes are based on a homogeneous Standard steam manifold installation:

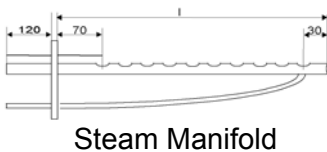
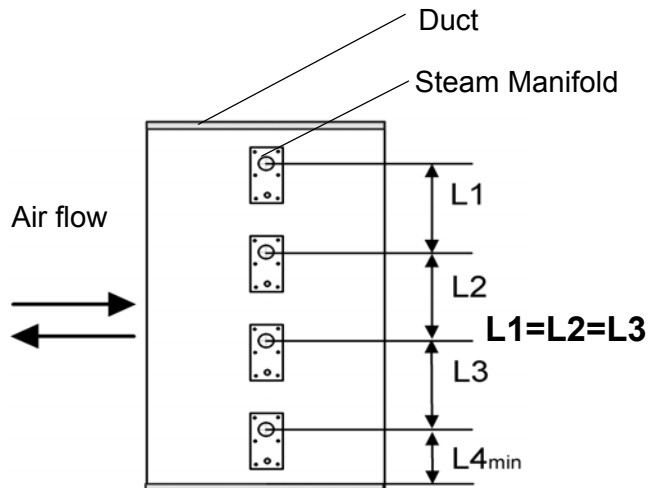

An even distribution of steam manifolds ensures a uniform steam distribution.

Please use the total height of the duct!

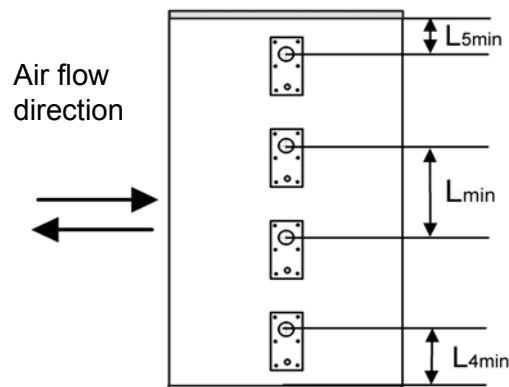

Minimum distances in order to avoid condensation:

**L<sub>min</sub> = 210mm**: distance „ steam manifold - next steam manifold“

**L4<sub>min</sub> = 120mm**: distance „lowest steam manifold - duct bottom“:**L5<sub>min</sub> = 120mm**: distance „highest steam manifold - duct ceiling“

Installations depending on special designs of air ducts:

Air duct	Positioning of steam manifolds	Sample																
flat	Staggered vertically and laterally																	
very flat	By tilting the steam manifold 30 - 45° towards the air flow direction, the minimum upper clearance can be reduced to 70mm. <table border="1" style="margin-top: 10px;"> <thead> <tr> <th colspan="4">min. distances: H1[mm]   H2[mm]</th> </tr> <tr> <th></th> <th>30°</th> <th>45°</th> <th></th> </tr> </thead> <tbody> <tr> <td>DN25</td> <td>182</td> <td>168</td> <td>225</td> </tr> <tr> <td>DN40</td> <td>193</td> <td>179</td> <td>230</td> </tr> </tbody> </table>	min. distances: H1[mm]   H2[mm]					30°	45°		DN25	182	168	225	DN40	193	179	230	very flat duct Narrow channel 
min. distances: H1[mm]   H2[mm]																		
	30°	45°																
DN25	182	168	225															
DN40	193	179	230															
narrow, high	Identical lengths one on top of the other. Staggered laterally if possible.																	
square	Identical lengths, staggered vertically and laterally																	
low, very wide	facing each other																	

**Vertical installation of steam manifold**

Steam manifold placement:

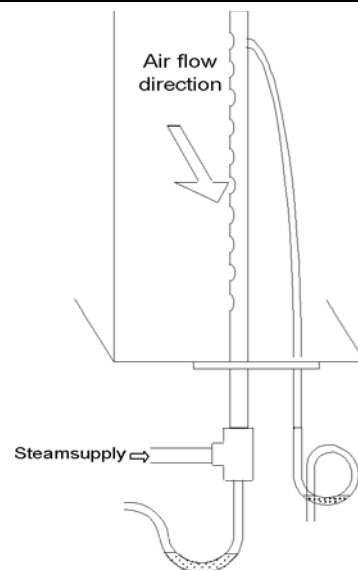

Horizontal installation of the steam manifolds is preferred. However, installation from below into the air duct is possible.

**Note:**



- Install the steam manifold horizontal with it ensure a clean steam out.
- Maximum allowable pressure in the air duct is 1200 Pa.
- On the return side, the maximum allowable negative air pressure is 500 Pa. Placement of the steam manifold on the supply side of the air duct is preferred.
- With high-pressure air-conditioning systems, the unit's drain hose system must be modified depending on the over pressure. When this is the case please consult HygroMatik.
- Install the steam manifold as close as possible to the steam humidifier in order to minimize steam loss through condensation.
- Depending on the design of the air duct, additional mounting of the steam manifold may be required. Shown installation and position dimensions are based on experimental values. Special environmental conditions could require adjustments.
- We note that the German Association of Engineers (VDI) Guideline 6022 specifies a water drain within the absorption distance inside the air duct.
- For steam bath applications: Install the steam manifold safe from contact with people in order to prevent injuries or burns. Do not install the steam manifold near a temperature sensor or inaccurate readings may result.
- Air flow rates over 3m/s can possibly lead to condensate drainage problems at the steam manifolds which may require adaptation measures.

**Length of steam manifold [mm]\*:**

I	220	400	600	900	1200	1450
DN25	x	x	x	x	x	x
DN40	x	x	x	x	x	x

\* special lenght on request

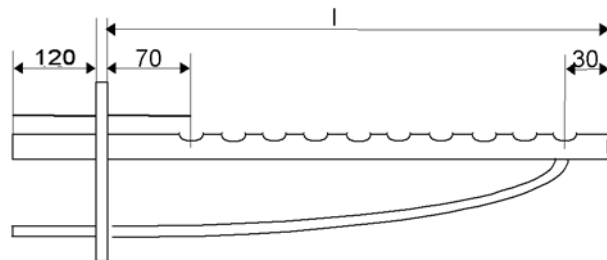

**Note:** At lengths of 600mm or more, steam manifolds are shipped with an extra alternative mounting fixture (Nut, M8) on the closed end.



The number and size of appropriate steam manifolds, as well as the nominal width of their respective steam and condensate hoses, are found in the tables below.

**HyLine:**

Type	Steam Manifold	Steam Hose	Condensate hose
HY05-HY17	1xDN25	DN25	DN12
HY05DS - HY17DS (for SPA)	1xDN40	DN40	DN12
HY23-HY30	1xDN40	DN40	DN12
HY45-HY60	2xDN40	2xDN40	2xDN12
HY90-HY116	4xDN40	4xDN40	4xDN12

**CompactLine:**

Type	Steam Manifold	Steam Hose	Condensate Hose
C1-C17	1xDN25	DN25	DN12
C10-DS, C17DS (for SPA)	1xDN40	DN40	DN12
C22, C30	1xDN40	DN40	DN12
C45**	2xDN40	DN40	DN12
C58	2xDN40	2xDN40	2xDN12

**HeaterCompact:**

Type	Steam Manifold	Steam Hose	Condensate Hose
HC3-12*	1xDN25	DN25	DN12
HC16-27	1xDN40	DN40	DN12
HC3-27 (for SPA)	1xDN40	DN40	DN12

**DBE:**

Type	Steam Manifold	Steam Hose	Condensate Hose
DBE 1-6	1x25	DN25	DN9
DBE 10-17	1x25	DN25	DN12
DBE 30	1x40	DN40	DN12
DBE 45	2x40	DN40	DN12

**HeaterLine:**

Type	Steam Manifold	Steam Hose	Condensate Hose
HL 6-12 *	1xDN25	DN25	DN12
HL 6-12 (for SPA)	1xDN40	DN40	DN12
HL 18-30	1xDN40	DN40	DN12
HL 36-45 **	2xDN40	1xDN40	1xDN12
HL 60-90 ***	2x(2xDN40)	2x(1xDN40)	2x(1xDN12)

\* For units HL 6 - 12 and HC3-12 HygroMatik delivers one adapter DN40 / 25 (but not for SPA applications)..

\*\* For units HL 36 - 45 HygroMatik delivers one t-connector for separating the steam on two steam manifolds.

\*\*\*HI 60.-90 are double units and consist of HI 30-45 units.

## 5.5 Cover Plate

HygroMatik flange plates may be used to neatly complete installation of the steam humidifier in the air duct.

Two-piece flange plates are available for the DN25 and DN40 steam manifolds.

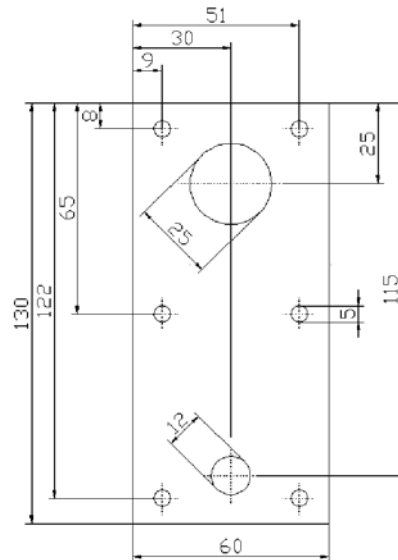

flange plate DN25 E-2604260

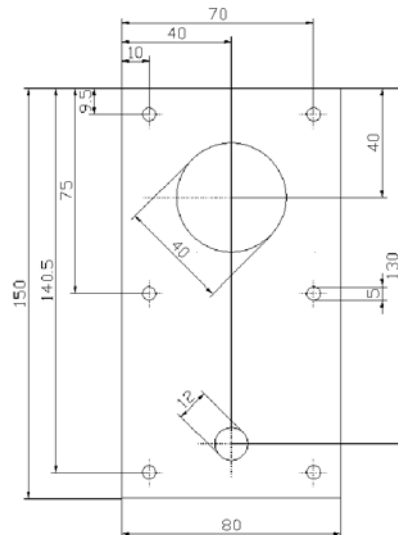

flange plate DN40 E-2604410

## 5.6 Drill Pattern

### 5.6.1 Drill Pattern DN25 (not to scale)

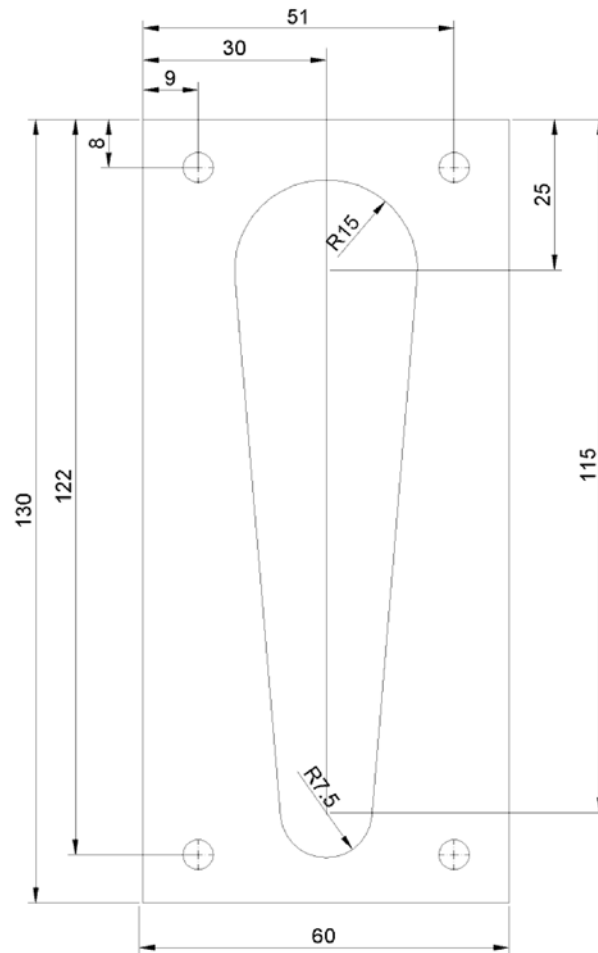

**Note:** Due to variable print media the dimensions are not to scale.

### 5.6.2 Drill Pattern DN40 (not to scale)

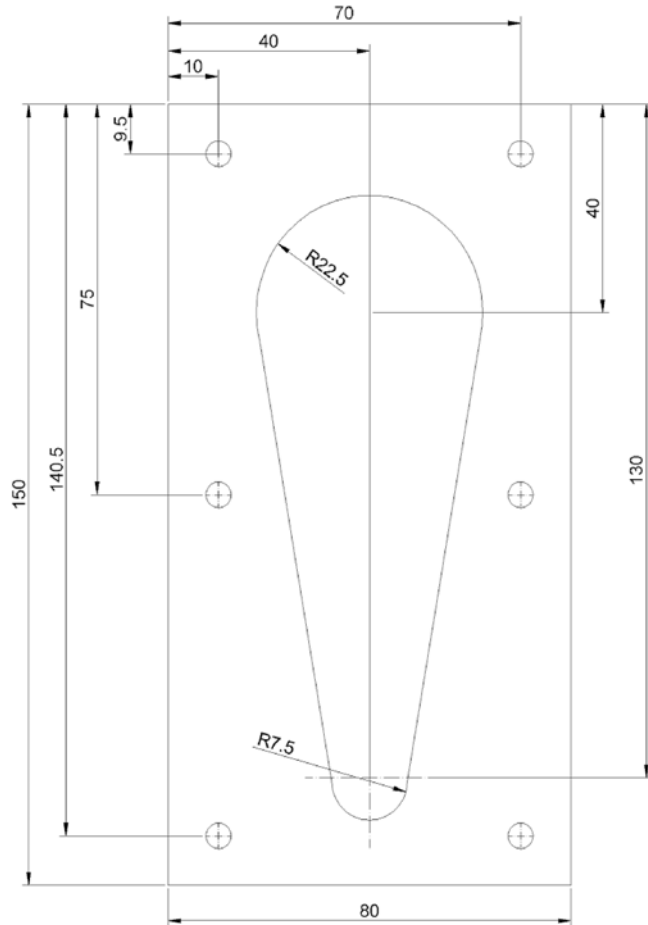

**Note:** Due to variable print media the dimensions are not to scale.

## 5.7 Steam Line



**Note:** When installing the steam hose, please pay attention to the following:

- The steam hose diameter may not be smaller than the steam outlet of the HygroMatik steam humidifier (do not restrict the cross-section, otherwise back pressure will increase).
- The steam hose must be without sags and kinks and be laid with a continuous slope of 5-10% (otherwise sags will be formed).
- The steam hose should be as short as possible. In case of lengths of over 5 m the hose should be insulated to avoid excess condensation.
- In the case that steam output is distributed on two steam manifolds the Y-pieces for the steam and condensate hose should be installed near the manifolds. If the installation is carried out in this way only one steam hose is necessary for the main part, the loss of condensate will be decreased. In deviation of this the y-piece that is delivered ex works with a humidifier type C45, HL36, HL45 should be installed near the humidifier.
- Depending on how the hose is laid, hose clips should be set at intervals of approx. 500 mm.
- Allow access to the steam hose, so that it can be inspected later.
- In case of straight lengths of several meters, it is recommended to place the steam hose in temperature resistant plastic pipe (40 mm dia for hose DN25; 60 mm dia for hose DN40) or to use copper pipe.
- Device output, steam line installation, and the duct influence of pressure condition in the duct. In an exceptional case this could mean to optimize the steam line installation.
- Only genuine HygroMatik hoses are capable of withstanding the operating conditions. Allow for minimum bending radii:  
Steam hose DN 25:  $R_{min} = 200 \text{ mm}$   
Steam hose DN 40:  $R_{min} = 400 \text{ mm}$

## 5.7.1 Types of Installation

### Installation type 1

**If the steam manifold is positioned higher than 500 mm above the steam humidifier:**

- » Lay the steam hose at a height of at least 400 mm above unit and then connect to the steam manifold with a constant rise or fall.
- » Lay condensate hose with a slope to the steam cylinder.
- » Lay a loop as a vapor trap. The steam manifold must be at least 500 mm from the loop. Fill loop with water before commissioning the system.

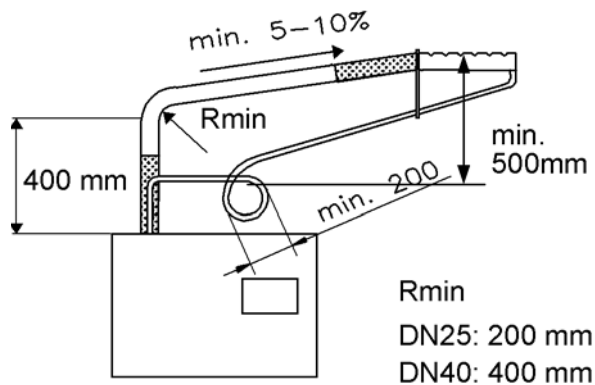

## Installation type 2

**If the steam manifold is positioned lower than 500 mm above the steam humidifier:**

- » Lay steam hose at a height of at least 400 mm above unit and then connect to the steam manifold with a constant fall.
- » Lay condensate hose with a loop of 200 mm diameter (vapour trap) to the drain. The distance between vapour trap and steam manifold should have at least 500mm.

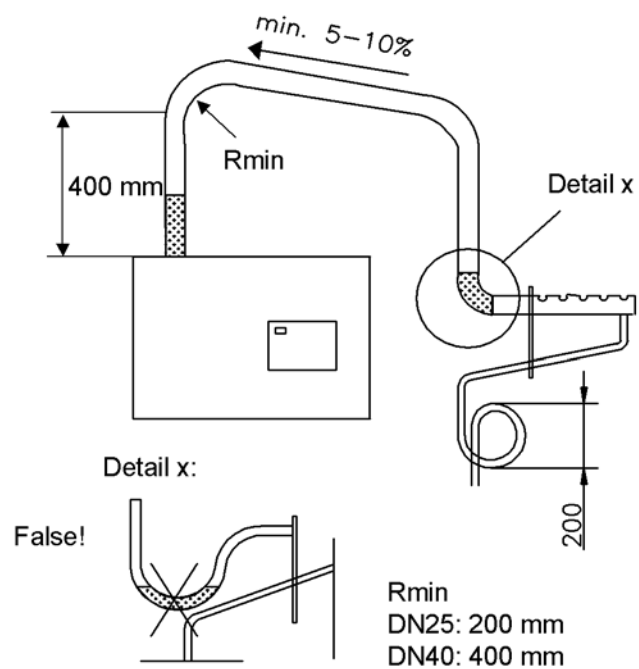

- » Lay the loop of condensate hose 200 mm directly above the drain.

## 5.8 Condensate Hose



**Note:** When installing the condensate hose, please pay attention to the following:



**Warning:** To keep condensate from accumulating in the duct, make sure condensate can drain freely.

### Installation type 1

**If the steam manifold is positioned higher than 500 mm above the steam humidifier:**

- » Condensate can be led to the steam cylinder (alternative the condensate can led to an outlet). For that purpose please use a part set that is included in the delivery. The part set consists of component N1 (t-piece), N2 (hose clamps) and N3 (hose).
- » **1.:** Remove yellow condensate plug (P) from manual drain hose (O). (The manual drain hose is normally used to drain the cylinder when there is no power supply for the drain pump.)
- » Lead the open end of the condensate hose through the hole in the top of the humidifier's cabinet.



**2.: Note:** Depending on the type of HeaterLine humidifier it is necessary to use one or two manifolds / condensate hoses. Therefor there are two type of connecting the condensate hoses:

- » Using a HeaterLine humidifier type HL6/ HL12/ HL18/ HL24 or HL27 (= 1 steam manifold required) the little stainless steel tube (N2) is connect to the manual drain hose (O). Please use a clamp. **3.:** Now the condensate hose is connected to the open end of the stainless steel tube (N2). To fasten the hose use a clamp.
- » Using a HeaterLine humidifier type HL30/ HL36/ or HL45 (= 2 steam manifold required) the middle outgoing of the t-piece (N1) is being used to be connected to the manual drain hose (O). Please use clamp **3.:** Both open outgoing of the t-piece are now used to connect two condensate hoses that are coming from the steam manifolds. Use clamps.



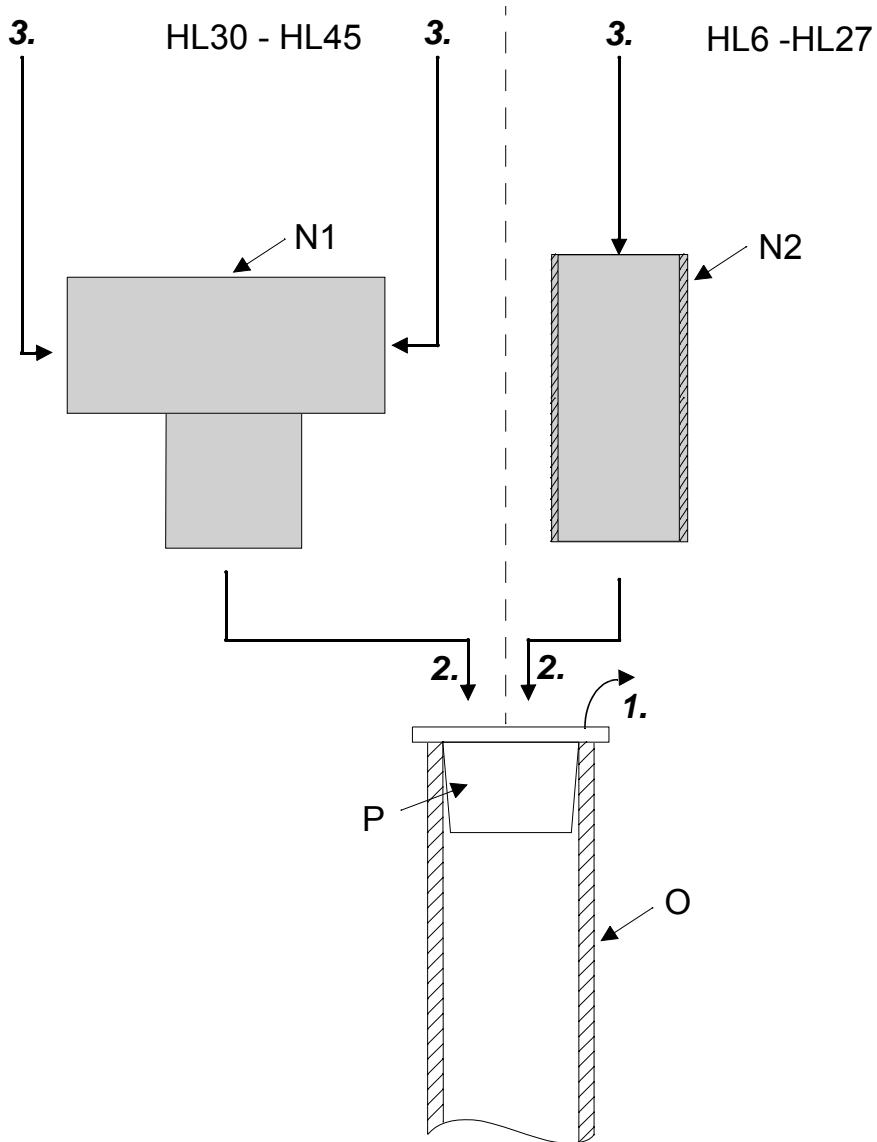

Connection condensate hose / hoses

Lay the condensate hose at an approximate incline of 5-10% to the steam cylinder connection fitting, to allow the condensate to drain freely.



**Note:** It is recommended to form a loop of 200 mm diameter as a vapour trap provided there is enough space. Possible operating noises can be reduced in this manner.

## Installation type 2

**If the steam manifold is positioned lower than 500 mm above the steam humidifier:**

- » The condensate must be drained separately.
- » To prevent steam loss, lay a loop at least 200 mm in diameter.
- » To ensure condensate drainage, place the loop (vapor trap) as far away as possible below the steam manifold connection.
- » The manual drain hose (O) must be closed with the stopper (P).
- » Place hose clamps at intervals of at least 500 mm, depending on how the hose is laid.

## 5.9 Steam Solenoid Valves

When humidifying a number of loads, which are to be controlled separately, using a single steam humidifier, steam solenoid valves can be included in the steam hoses. Valve control has to be provided by the customer.

- Install the vertical risers with flow from bottom to top.
- The best position is just above the steam humidifier.

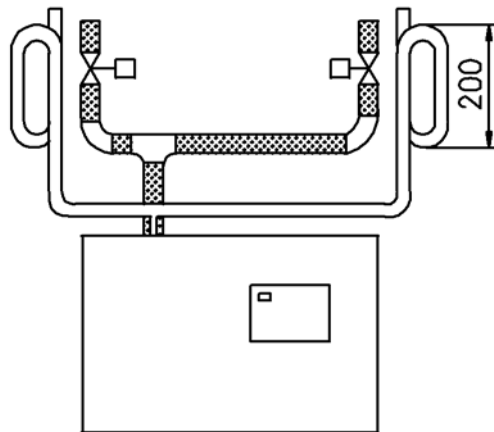

Installation of Steam Solenoid Valve

## 5.10 Chimney-compartment

Between electrical compartment (right side) and steam production compartment (left side) the chimney compartment is located. The chimney compartment is used to cool electronic components. For proper function make sure that the three holes in the top side of the housing are not covered - otherwise the heat removal is too low and a thermal cutout could be triggered.

## 5.11 Unit Installation Check



**Attention:** This unit may only be operated by qualified and properly trained personnel.

Please check the installation using the following list:

- Does unit hang vertically?
- Are wall distances to the unit within the range
- Does steam hose have a slope of 5-10%?
- Is condensate hose installed with a loop of min. 200 mm?
- Is steam manifold positioned correctly?
- Are all bolts and clamps tightened?
- Is steam manifold installed horizontaly?
- Are all sealings installed?
- tAre the three holes in the top side of the housing not covered?

## 6. Water Installation



**Warning:** For installation, note the following:

- Have all work performed by a professional.
- Disconnect power supply prior to installation. Obey regulations of local public utilities.
- Verify that necessary safety measures have been taken - in compliance with either German Technical and Scientific Association for Gas and Water (DVGW) guidelines (DIN EN1717) or local regulations - to eliminate backflow of polluted water into drinking water treatment facilities. This can mean installing a system separator. Within the humidifier, two double check valves (58) are located in the water supply lines. They prevent - in accordance with DIN EN 61770 - the backflow of water.
- The water supply temperature may not exceed 40 °C.
- Flushed-out water must be able to drain freely.
- The water supply line must have a minimum diameter of DN 12 (3/8").
- If (chemical) additives are present in the humidification water, health risks and/or impaired unit operation cannot be ruled out. Use of additives is not advised unless specifically recommended by the unit manufacturer.
- When employing demineralized water or purified condensate, do not use copper or brass in the supply or drain lines of the HeaterLine unit. These materials can be corroded by demineralized water or purified condensate. Instead, use stainless steel or temperature-resistant plastic pipes.
- Water installation pressure: 1 to 10 bar ( $100 \times 10^3$  to  $100 \times 10^4$  Pa) .
- For water installation please use the water connecting hose that is delivered with the unit.

### 6.1 Water Quality

The HeaterLine Type steam humidifier is designed for use with:

- tap water with a total hardness of max. 18.8°e
- demineralized water (min. conductivity 3µS/cm)
- fully cleaned condensate (min. conductivity 3µS/cm)
- partially softened water

Boiling normal tap water always produces lime. Lime deposits on the surface of the heater elements may reduce their lifetime. We recommend to use a water treatment device in order to prevent scaling.

In case of any questions regarding water treatment devices please contact HygroMatik.

## 6.2 Water Supply (For Operation with Demineralized Water or Purified Condensate)

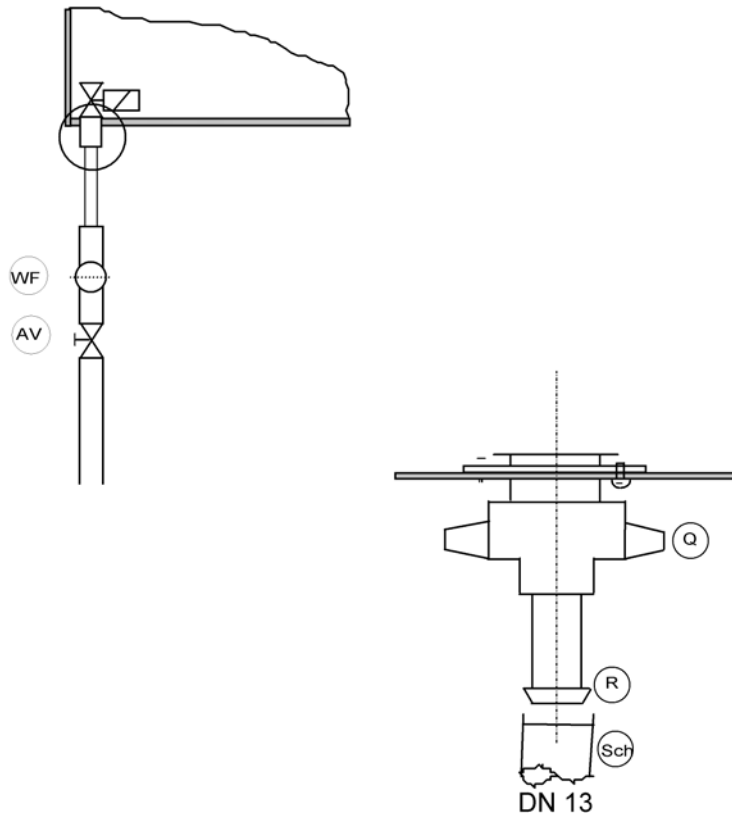

- » Install a shut-off valve (AV) in the supply hose
- » Install a water filter (WF) if the water quality requires it
- » Make sure that a backflow preventer is installed in the water supply line.



**Note:** Shut-off valve (AV), water filter (WF) and backflow preventer are not provided by HygroMatik.

Install as follows:

- » Check whether the valve strainer has been inserted in the solenoid valve.
- » Screw cap nut (Q) onto the supply connection. Tighten by hand.

The supply connection protrudes from the intermediate tray.



**Note:** Excessive tightening will damage the threads.

- » Slide 13mm inner diameter hose (SCH) over the pressure clip (R) and secure with a hose clamp.

### 6.3 Water Supply (For Operation with Tap Water or Partially Softened Water)

- » Install a shut-off valve (SV) in the supply line.
- » Install a water filter (WF) if water quality requires it.
- » Make sure that a backflow preventer is installed in the water supply line.



**Note:** Shut-off valve (SV) and water filter (WF) are not supplied with the unit

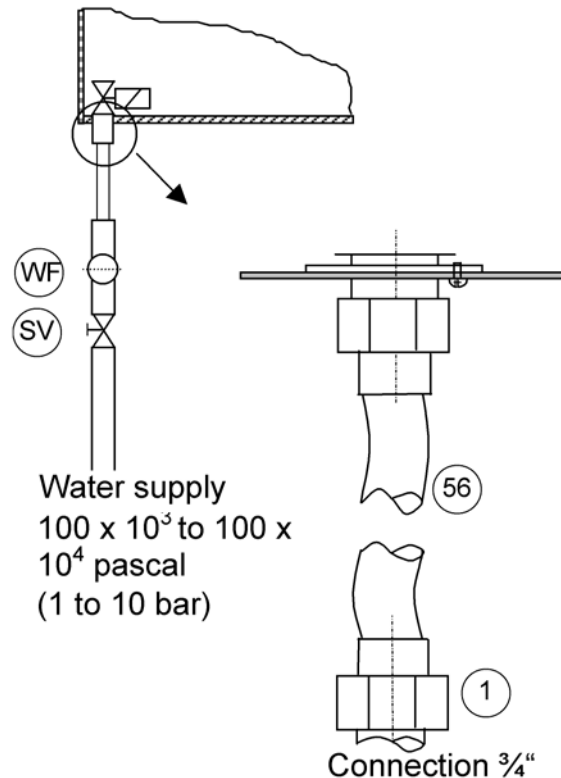

- » HygroMatik provides a water hose (56) with a cap nut at both ends which can be used for water installation.

Install as follows:

- » Screw and tighten the cap nut with its inner seal ring around the water supply screw connection that protrudes from the base.



**Note:** Tightening too much will destroy the fitting. The valve strainer (29) must be placed inside the solenoid valve.

- » Use a cap nut (internal thread  $\frac{3}{4}$ " ) with inner seal for a customer-provided water installation.

### 6.3.1 Feed from Holding Tank

If a holding tank will be used to supply water, the „option solenoid valve 0-10bar” must be ordered. Make sure that the feed height is at least 0.5 meter. If the height is less than 0.5 m, insert a feed pump or install the humidifier lower if possible.

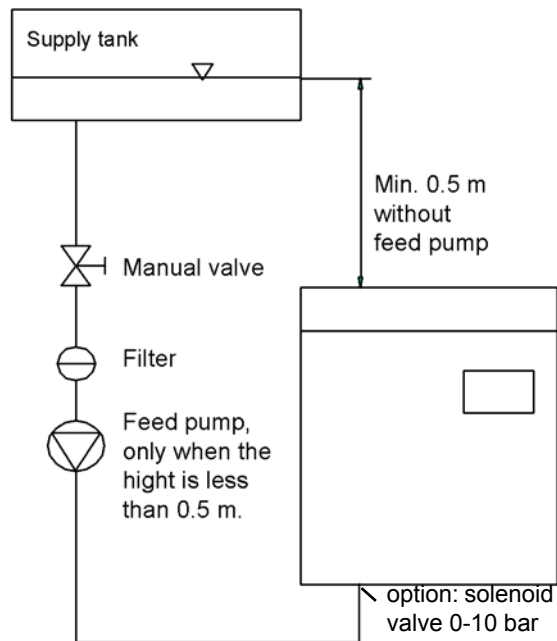

### 6.4 Water Treatment

For water treatment system specifications, use the following table.

The figures below assume that the humidifier has been running for 24 hours at 100% output.

HeaterLine	Max. Water Consumption in over24 h [l]
6	166
9	248
12	331
18	497
24	662
27	754
30	828
36	994
45	1242

## 6.5 Water Discharge



**Warning:** Please pay attention to free and non-pressure drainage of the water! During blow down up to 0,3L/s is being drained. For water discharge, we recommend installation of a flexible water drain hose. Humidifier and waste water discharge must be on the same pressure level.

Please note:

- Do not bend, shorten or lengthen the drain hose.
- For the discharge line and drain pipe, select materials temperature-resistant up to 95°C.

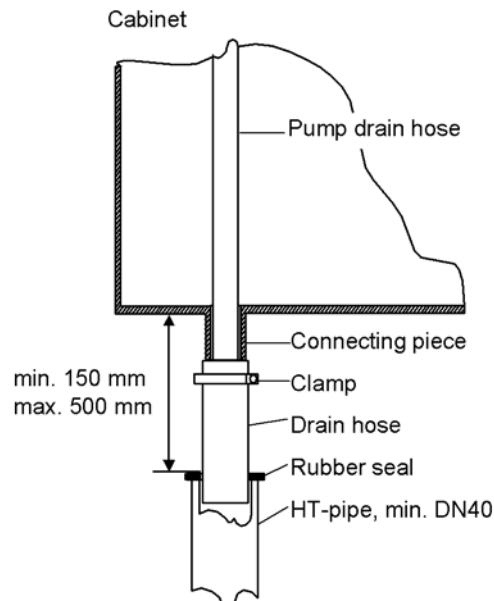

Install the water drain system as follows:

- Run 250 - 1000 mm length of 1 1/4" drain hose loosely into a drainpipe with a minimum inner diameter of 40 mm.

Type	Drain Hose
HL 6-45	1 x 1 1/4"

- Slide the drain hose over the pump discharge hose and secure to the cabinet drain connection.

A grounding clip is fixed on the inner surface of the cabinet drain connection. Slide the end of the pump drain hose onto this clip. During blow-down, the grounding clip will be in direct contact with the water and will conduct any residual currents which may appear away from the cabinet.

There is a 3mm-wide gap between the pump drain hose jacket and the inner surface of the cabinet drain connection. If water collects on the base plate, it will flow through this gap into the drainage system.



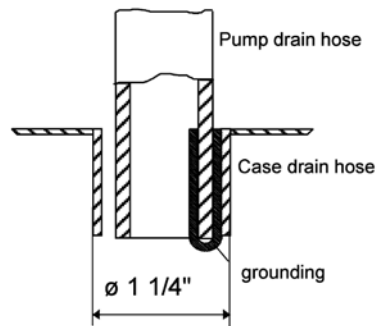

## 6.6 Checklist

Verify correct system installation using the checklist below:

- Can flushed-out water drain freely?
- Have all screws and clamps been properly tightened?
- Is the water supply line properly flushed out?
- Has the water installation been performed correctly?

Is the drainage system correctly installed?

Are the water supply and drain lines free of leaks?



**Warning:** Flush out the water supply line before connecting to the solenoid valve, especially when installing a new line. This prevents dirt particles from damaging the solenoid valve.

## 7. Electrical Installation

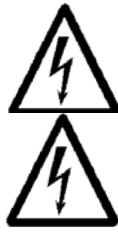

**Warning, Hazardous Voltage!** All work related to electrical installation may be performed by authorized personnel only (electricians or professionals with equivalent training). The customer is responsible for checking qualifications. **Warning, Hazardous Voltage!** Do not connect the steam humidifier to the power grid until after all installation work has been completed. Please obey all local regulations concerning electrical installation.



**Warning:** The electronic components of the humidifier control are very sensitive to electrostatic discharges. In order to safeguard these components during installation and servicing, steps must be taken to protect against ESD.



**Warning:** For installation, note the following:

- Disconnect power supply prior to installation and secure against restart.
- Verify the absence of electric current.
- Installation or removal of the display and control unit may only be performed when the unit is switched off. See also section "Access to Control."
- Electrical connector cables must be wired by qualified personnel.
- Install electrical connections as specified in the wiring diagrams.
- For units with power ratings over 33 kW, only a permanent connection to a permanent installation is permitted (observe European Directives shown in chapter „EC Declaration of Conformity“).
- Ensure that all terminals have been tightened.

### 7.1 Electrical Installation

- » Breakers must have a contact gap of at least 3 mm per pole.
- » Each steam cylinder requires a separate main power supply including main fuses, main breaker, etc.
- » Connect potential equalization inside the unit to the external ground bolt (located on the underside of the cabinet beside the cable connections).

Observe European Directives shown in chapter „EC Declaration of Conformity.

- » Install main power supply as follows:

Type	Main Power Supply
HL6-45	400V/3Phases/N

We recommend using a main fuse with medium blow rating (applies only to the mains voltages above.) See table below indicating maximum power consumption corresponding to each type of circuit protection:

Type	Power Consumption	Fuses
HL6	11,3 A	3x16 A
HL9	16,9 A	3x20 A
HL12	19,5 A	3x25 A
HL18	29,3 A	3x35 A
HL24	39,0 A	3x40 A
HL27	29,3 A	3x35 A
HL30	39,0 A	3x40 A
HL36	58,5 A	3x63 A
HL45	58,5 A	3x63 A
HL60	2 x 39,0 A	2 x (3x40) A
HL70	2 x 58,5 A	2 x (3x63) A
HL80	2 x 58,5 A	2 x (3x63) A
HL90	2 x 58,5 A	2 x (3x63) A

## 7.2 Cable Connections

The table below shows the cable connections provided in HeaterLine steam humidifiers:

Unit	Connection M16	Connection M25	Connection M32
HL6 - 45	4	2	1

Characteristics of metric cable connections:

Thread	across-flats dimensions [mm]	for cable diameter [mm]
M16x1,5	19	4,5 - 10
M25x1,5	30	9 - 17
M32x1,5	36	11 - 21

## 7.3 Control Connection



**Warning:** Set the control to prevent overly frequent activation and deactivation of the steam humidifier. Main contactors are wearing parts and are guaranteed by the manufacturer for 150,000 cycles. Operation which minimizes activation cycles will extend the life of the main contactors.

## 7.4 Fan Unit

» Connect fan unit as specified in the wiring diagram.

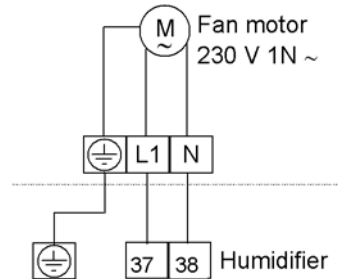

The fan unit is activated/deactivated in parallel with humidification.



**Note:** Terminals 37 und 38 are supplied with the unit only when the fan unit and humidifier are purchased simultaneously. In other cases (i.e. retrofitting) the fan unit motor phase can be connected to Terminal 2 guided via the auxiliary contact of the main contactor.

Only cables with same diameter are allowed to be connected to one common clamp.

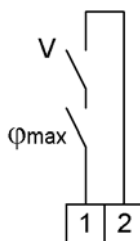

Terminals Humidifier

## 7.5 Safety Interlock

Between terminal 1 and 2 of the humidifier the so called safety interlock is located. If the safety interlock is not closed the humidifier is not allowed to work.

Any additional safety devices (see below) have to be installed between those terminals. The safety interlock is also used for an On/Off control mode.

There is no jumper between terminal 1 and 2 ex works.



**Note:** Install contact interlocks, i.e. max. hygostat, vane relay, pressure controller, air interlock etc. in series between Terminals 1 and 2.



**Warning:** It is standard practice for air-conditioning to install a max. hygrostat in the safety interlock (not valid for steam bath applications). The max. hygrostat acts as a safety device in the event of a humidity sensor malfunction and protects against overhumidification.



**Warning:** Contacts laid between Terminals 1 and 2 must be potential free and rated for 230V switches. Terminal 1 is supplied with 230V AC after switching on the humidifier.

## 7.6 Wiring Diagram

Please refer to the wiring diagram in the technical manual supplied with the control used with your humidifier. Every steam humidifier comes with a unit-specific technical manual and a manual for the control. In addition, you will find downloadable wiring diagrams and technical manuals at [www.hygromatik.de](http://www.hygromatik.de).

## 7.7 Electrical Installation Checklist

Perform electrical installation checks in compliance with customer site requirements and public power utility regulations:

- Does the mains voltage match the voltage on the name plate?
- Have all electrical connections been made according to the terminal diagram?
- Have all electrical cable and plug connections been properly tightened?
- Are all electrical plug connections secure?
- Is the unit grounded?

After this check the unit can be switched on.



**Warning:** The unit must be closed and locked (only for humidifier type HeaterLine). This guarantees that the cover is grounded.



**Note:** For initial operation, control, service, malfunctions, and circuit diagrams, consult the operation instructions for the Hygro-Matik-controls or at [www.hygromatik.de](http://www.hygromatik.de).

## 8. Commissioning



**Warning:** This unit is only to be started by qualified personnel.

### Switching off steam humidifier



**Warning:** Before starting up the unit, make sure you know how to switch it off.

- » Switch off unit by setting control switch to “0”
- » Close water supply stopcock valve.

### Check of electrical wire connections

- »
- » Check that all electrical wire connections, including heater element wire connections, are tight and secure.
- » Check cylinder seating, and if necessary steam and condensate hose clamps.

### Switching on Steam Humidifier

- » Switch on main breaker.
- » Open water supply stopcock valve. Operating pressure  $100 \times 10^3$  to  $100 \times 10^4$  Pa (1 to 10 bar overpressure).
- » Switch on unit by setting control switch to “1”.
- » Set control of initial operation check to humidity demand.

The following functions are operating:

- The unit performs a self-test. If the control includes a display, the message “self-test“ is displayed.
- If the safety interlock (see also chapter „Safety interlock“) is closed, the water inlet solenoid valve opens and feeds water into the steam cylinder.
- If there is a demand for humidity, the main contactor is switched and a few minutes later steam production starts. Initiation of steam production can take up to 20 minutes.

### Further checks:

- Let all electrically-driven operations run to completion.

As soon as the solenoid valve begins replenishing the water periodically, the steam humidifier operates at steady nominal output and the cold start sequence is complete.

- » Monitor the unit and let it operate for 15 to 30 minutes. If leaks appear, switch off the unit.
- » Repair leaks, and in doing so:



**Attention, Hazardous Voltage!** Follow safety instructions for work on live components.

## 9. Maintenance

The HygroMatik steam humidifier is easy to maintain. Nevertheless, inadequate or improper maintenance can lead to operational malfunctions. Perform regular maintenance to give your unit a long life span.

Since steam and condensate hoses are also subject to wear they have to be checked regularly.



**Warning:** When performing maintenance work, please follow these instructions:

- During operation and also for a while after switching off the unit the steam cylinder is hot. Before touching the cylinder, check its temperature.
- Have the unit serviced only by qualified, authorized personnel.
- Obey safety regulations.
- Switch off the unit prior to maintenance and secure against restart.
- After maintenance work, have qualified personnel check that the unit is operating safely.

The steam humidifier's performance and maintenance intervals depend primarily on the existing water quality and the quantity of steam generated. Variable water quality can lengthen or shorten the maintenance interval. Ongoing maintenance intervals can be estimated based on the amount and type of residue found in the steam cylinder. Immediate cylinder maintenance is indicated by:

- a **green, blinking LED** on the display and operating panel.
- the display reads **Service** (only with controls of Type Comfort and Comfort Plus).

## 9.1 Maintenance for Operation with Demineralized Water / Condensate

Instructions for maintenance and cleaning intervals are based exclusively on typical, empirically determined values.

Cycle	Maintenance Task
<b>4 Weeks after Initial Operation</b>	Visual check of electrical and mechanical connections.  Visual check of water level control.  Visual check of steam cylinder interior.
<b>Annually</b>	Visual check of electrical and mechanical connections.  Visual check of water level control.  Visual check of heater elements / thermo sensor.  Visual inspection of interior of steam cylinder.  If needed, cleaning of steam cylinder, heater elements and thermo sensor.



## 9.2 Maintenance for Operation with Tap Water or Partially Softened Water

No precise maintenance intervals can be specified because these always depend on water quality and quantity of steam generated. It is advisable to adjust the frequency of maintenance to the specific operational application.

HYGROMATIK recommends to open and check the steam cylinder two weeks after commissioning. Ongoing maintenance intervals can be estimated based on the amount and type of residue found in the steam cylinder.

### Blow-Down Cycles

The vaporization process causes mineral (calcium) deposits of different compositions to settle in the steam cylinder. Part of this solid build-up is removed through periodic blow-downs and fresh tap water refills with the aid of the HygroMatik SUPER FLUSH flushing system.

The SUPER-FLUSH system generates a whirlpool effect in the strainer basket, intensifying removal of calcium particles during blow-down.

### Water quality

When using tap water, note that cleaning intervals shorten as the carbonate hardness level in the water increases. As a general rule, it is preferable to operate the unit with fully demineralized water. Operation will not be affected by mineral deposits and flushing losses will be minimized.



**Note:** If desired, maintenance intervals can be lengthened by moderately increasing blow-down rates. Please consult HygroMatik.

### 9.3 Access to Control Unit

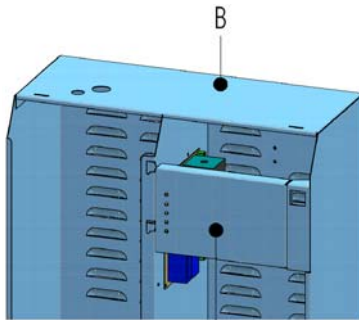

- » Remove cover (or electric compartment cover) and lift display panel (A) out of its guide.
- » Turn display panel (see drawing) and hang display panel on the humidifier cabinet (B) by placing the two guide pins in the two front guides.

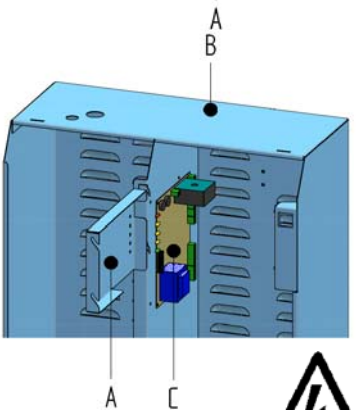

- » The PCB (C) is now accessible.



**Danger, Hazardous Voltage:** Switch off unit before installing or removing the display plate.

### 9.4 Cleaning the Coarse Strainer in the Cylinder Base

#### Removal

- » Shut off water supply.
- » Drain steam cylinder by setting main switch to Pos II.
- » Disconnect power supply and secure against restart (set main switch to Pos 0, switch, remove main fuse and control fuse F1). Verify the absence of electric current.
- » Remove connector plug for steam cylinder lead.
- » Twist and remove star screw on the steam hose adapter.
- » Remove clip on the steam hose adapter (2).
- » Push the steam hose adapter up out of the cabinet and secure with the clip.
- » Undo clamping belt.
- » Lift steam cylinder (9) out of the base (11).



Warning: When lifting the cylinder be aware not to damage the heating element cable.

- » Remove cylinder base o-ring (13).
- » Lift strainer insert (12) out of the base using the two access holes on the side.
- » Remove all deposits from the coarse strainer.
- » Keep coarse strainer clean with mechanical utilities.
- » Check base for deposits and remove if necessary. Especially the passes of the hose connections should be checked.
- » Insert coarse strainer and position correctly by clicking the cut-out into place in the clip.

### Assembly

- » Thoroughly clean o-ring seating in cylinder base. No calcium residue can remain behind on the seating.
- » Moisten new cylinder base o-ring and insert in base.
- » Remove o-ring (4) from the steam hose adapter (2).
- » Moisten o-ring fluid and place on the upper part of the cylinder collar on the cylinder cover (5).
- » If necessary, replace o-ring seal between cylinder (9) and cylinder cover.

To do this:

- » Loosen clamping belt and lift off cover.
- » Remove o-ring (15).
- » Insert new o-ring, replace cover . Close clamping ring.



**Warning:** To avoid harming fingers during closing of the clamping ring, make sure that your fingers are not in the closing range.

- » Push steam cylinder back into base with a gentle twisting motion.



**Warning:** When inserting the cylinder be aware not to damage the heating element cable



**Note:** The information sticker “hot surface” must be positioned at the front.

- » With a gentle turning motion, put adapter (2) over the o-ring on the steam outlet and fix it with the star screws.
- » Slide clip between adapter and cabinet.
- » Close clamping belt.
- » Attach steam cylinder connector plug.

- » Switch breaker back on.
- » Open water supply.
- » Switch on unit and check for leaks after 15-30 minutes of operation.

If leakage occurs, switch off power supply and repair the leaks, following safety instructions for work on live components!

## 9.5 Cleaning Steam Cylinder

### Removal

- » Close off water supply.
- » Drain steam cylinder (9) by setting main switch to Pos II.
- » Disconnect power supply and secure against restart (switch off control switch, remove main fuse and control fuse F1).
- » Verify absence of electric current.
- » Remove steam cylinder as described in section "Cleaning Coarse Strainer in Cylinder Base."
- » Open cylinder clamping ring (7) and lift off cover (5) with heater elements (8).

### Cleaning

When using mineral deposit removers or cleaners to clean the cylinder and heater elements, make sure you thoroughly rinse the unit before returning reassembling it. Use mineral deposit removers **only** for cylinder and heater elements.



**Note:** Overly strong mechanical cleaning can damage the cylinder / heater elements.

- » Remove all deposits. However, small amounts of scale deposits on the heater elements (8) are harmless.

### Assembly

- » Install cylinder (9) as described above in section "Cleaning Coarse Strainer in Cylinder Base."

## 9.6 Cleaning connection hoses, cylinder base and nozzle

All connection hoses should be free of deposits and in good conditions.

Please check all connections of the cylinder base (11) for deposits and remove if necessary.

When operating with partially softened water or tap water scale can be discharged with the steam flow and can settle in the nozzle (3) that is in the steam hose adapter. Therefore, this nozzle should be tested regularly as part of the general maintenance review and cleaned if necessary.

## 9.7 Replacing Heater Elements

### Removal

- » Close off water supply.
- » Drain steam cylinder (9) by setting main switch to Pos II.
- » Disconnect power supply and secure against restart (switch off control switch, remove main fuse and control fuse F1).
- » Verify absence of electric current.
- » Remove steam cylinder as described above in section "Cleaning Coarse Strainer in Cylinder Base."
- » Open cylinder clamping ring (7) and lift off cover (5) with heater elements (8).
- » Detach connecting cable for the heater element in question. Mark these two terminals.
- » If necessary, remove the capillary tube from the thermo sensor by detaching the retainer clips.
- » Detach the heater elements from the cover by removing the nut from the pressure plate (16).
- » Clean the sealing surface on the underside of the cover around the area where the new heater element will be installed.

### Installation

- » Install new heater element, replacing the parts in the correct sequence according to the diagram, and screw nut with a torque of 5Nm onto the pressure plate.
- » Insert the heater element's connecting cable into the two marked terminals and tighten. Polarity of (heater element) connecting cable is not important.
- » If necessary: Install capillary tube on the thermo sensor

using retainer clips.

- » To proceed further, follow the steps described above in section “Cleaning Coarse Strainer Cylinder Base.”

## 9.8 Replacing Thermo Sensor (for Heater Element)

### Removal

- » Close off water supply.
- » Drain steam cylinder (9) by setting main switch to Pos II.
- » Disconnect power supply and secure against restart (switch off control switch, remove main fuse and control fuse F1).
- » Verify absence of electric current.
- » Remove steam cylinder connector plug.
- » Remove star screw from the steam hose adapter (2).
- » Remove clip on steam hose adapter.
- » Push the steam hose adapter up out of the cabinet and secure with clip.
- » Loosen clamping belt.
- » Lift steam cylinder out of the base (11).



**Warning:** When lifting the cylinder be aware not to damage the heating element cable.

- » Remove thermo sensor cap.
- » Loosen thermo sensor screw terminals and detach wires.
- » Loosen clips of capillary tube.
- » Disconnect capillary tube from the heater elements (8).
- » Remove locking nut (R) of thermo sensor (O)
- » Remove thermo sensor.

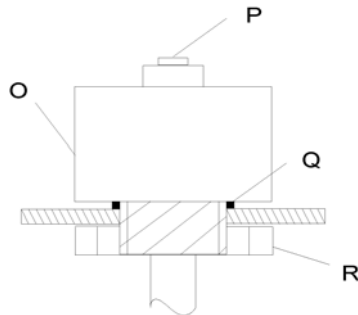

- O: Thermo Sensor
- P: Unlocking Button for Thermo Sensor
- Q: Seal
- R: Mounting Counternut



**Warning:** Do not bend the capillary tube of the thermo sensor!

### Installation

- » Install heater element and thermo sensor. Do not screw the nut in too tightly!
- » Neatly connect the capillary tube to the heater element. Having humidifiers with two or more heating elements the capillary tube is connected to two heating elements.
- » To proceed further, follow the steps described above in section "Cleaning Coarse Strainer in Cylinder Base."

### 9.8.1 Cleaning of the Control Cylinder

The control cylinder (6) monitors the water level. When cleaning the steam cylinder the control cylinder should also be cleaned. Therefore:

- » Loosen the four top screws that interconnect floating switch and control cylinder housing.
- » Pull out floating switch and clean it carefully.
- » Take off sealing and clean it.



**Note:** The rod assembly may not be lubricated.

- » Clean the sealing surface of the control cylinder housing.
- » For installation mount the a.m. components in reverse order.

### **9.9 Unlocking of a Released Thermo Sensor (for heater element)**

If a thermo sensor (for heater element) has released due to a too high temperature the blue button (P) is on the same level as the top of its holder. Additionally the control reports a failure „thermo sensor activated“. After the system has cooled down the release button (P) can be unlocked by pressing it down a few millimetres.

### **9.10 Unlocking of a Released Thermo Sensor (for Solid State Relay)**

If a thermo sensor (for solid state relay) has released due to a too high temperature ( $>100^{\circ}\text{C} \pm 5^{\circ}\text{K}$ ) the control reports a failure „thermo sensor activated“. After the system has cooled down the release pin (that lays between the both plain connectors) can be released by pressing it carefully down until there is a click sound.

### **9.11 Unlocking of a Released Thermo Sensor (cylinder cover)**

If a thermo sensor (for cylinder cover) has released due to a too high temperature ( $>105^{\circ}\text{C} \pm 5^{\circ}\text{K}$ ) the control reports a failure „thermo sensor activated“. After the system has cooled down the release pin (that lays between the both plain connectors) can be released by pressing it carefully down until there is a click sound. This thermal switch is used for overall control of the radiator (principle: double check) and can only be triggered if there was a significant overheating.

If this thermal switch has tripped, the heater elements must be replaced.

### **9.12 Cleaning Blow-Down Pump**

- » Close off water supply.
- » Drain steam cylinder by setting the main switch to Pos II.
- » Disconnect power supply and secure against restart (switch off control switch, remove main fuse and control fuse F1).
- » Verify absence of electric current.



- » Detach electrical connector from the pump (10).
- » Detach union adapter (E) from the pump.
- » Remove screws (G) and take the pump out of the base (11).
- » Open pump (bayonet lock).
- » Remove all residue from the drain hoses and pump (possibly replace o-ring (A)).
- » Assemble pump.
- » Moisten o-ring (C) and place in the side connection of the base.
- » Push pump into the base and secure tightly with screws (G).
- » Moisten o-ring (D) and place on the side connection of the pump.
- » Slide union adapter (E) over the side connection of the pump.
- » Connect electrical connector to the pump (polarity not specified).
- » Open water supply.
- » Switch on unit and check for leaks after 15-30 minutes of operation.

If leakage occurs, switch off power supply and repair the leaks, following safety instructions for work on live components!

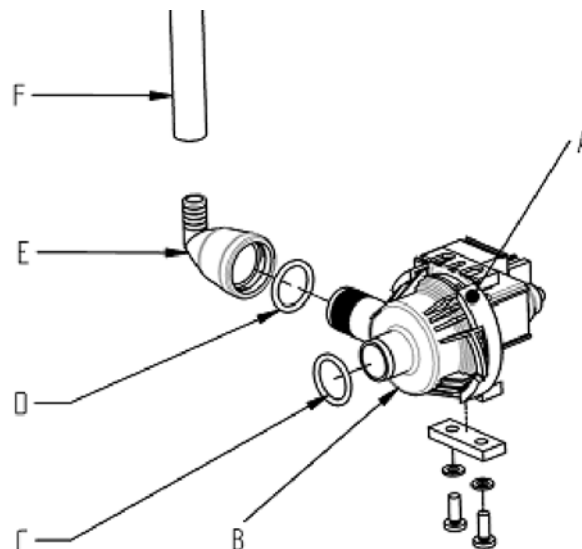

## 9.13 Removing Inlet Solenoid Valve and Cleaning Fine Mesh Filter

### Removal

- » Close off water supply.
- » Drain steam cylinder (9) by setting main switch to Pos II.
- » Disconnect power supply and secure against restart (switch off control switch, remove main fuse and control fuse F1).
- » Verify absence of electric current.
- » Remove cylinder as described above in section “Cleaning Steam Cylinder.”
- » Seal off water supply and remove screw joint from fresh water connection (L).
- » Detach connector hoses (G) from base (11) and mark a position.
- » Remove electrical connectors from double solenoid valve (H) and mark position.
- » Remove solenoid valve mounting screws (I).
- » Take the solenoid valve out of hole.

### Cleaning

- » Remove fine mesh filter (K) from the solenoid valve and clean.

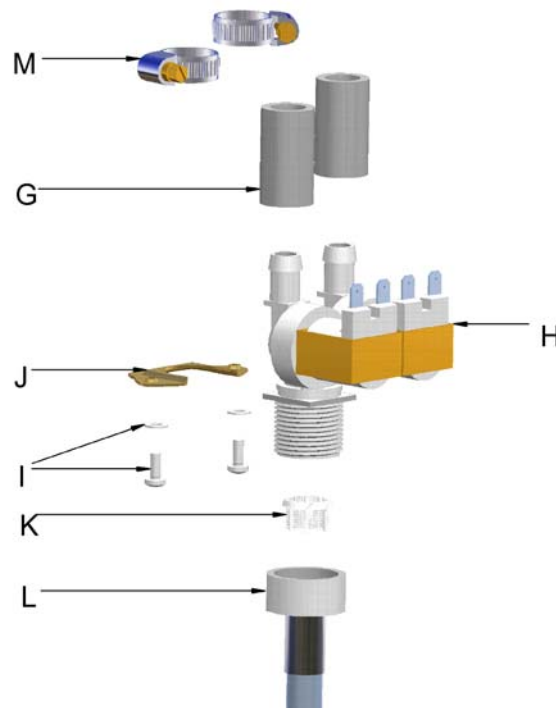

## Installation

- » Place solenoid valve with seal in the hole in the unit cabinet.
- » Secure solenoid valve tightly with screws (I).
- » Attach fresh water connection (L).
- » Connect electrical cable to the double solenoid valve. Take care to position correctly.
- » Attach connector hose (G) to the base by using clamps (M)..
- » Install cylinder as described above in section “Cleaning Steam Cylinder”.
- » Open water supply.
- » Switch on unit and check for leakage after 15-30 minutes of operation.

If leakage occurs, switch off power supply and repair the leaks, following safety instructions for work on live components!

### 9.14 Checking Cable Screw Connections, Heater Element Wires

- » Check that all cable screw connections are securely tightened
- » Ensure that heating element cable is not damaged.



**Warning:** Loose cable connections cause excessive contact resistance and overheating of contact surfaces.

### 9.15 Operational Check

- » Start up the unit and operate for a few minutes, ideally at maximum output..
- » Check safety devices.
- » Check hose connections for possible leaks.

### 9.16 Dismantling

Once the steam humidifier will no longer be used, dismantle (demolish or scrap) it by following the installation procedures in reverse order.



**Warning:** Dismantling of the unit may only be performed by qualified personnel. Electrical dismantling may only be performed by trained electricians.

Obey the safety guidelines in section “Safety Instructions,” especially the guidelines for disposal.

## 10. EC-Declaration of Conformity

### EG-Konformitätserklärung EC Declaration of Conformity

Hersteller: **HygroMatik GmbH**  
Manufacturer: *HygroMatik GmbH*

Anschrift: **Lise-Meitner-Straße 3**  
Address: *D-24558 Henstedt-Ulzburg / Germany*

**Produktbezeichnung / Product description:**

**Heater Line (HL):** HL06, HL09, HL12, HL18, HL24, HL30, HL36, HL45, HL60, HL70, HL80, HL90

**In den Ausführungen / Type:** Basic, Comfort, Comfort Plus, Dampfbad / *Steam bath (DS)*

**Die bezeichneten Produkte stimmen in der von uns in Verkehr gebrachten Ausführung mit den Vorschriften folgender Europäischer Richtlinien überein:**

*The products described above in the form as delivered are in conformity with the provisions of the following European Directives:*

**2004/108/EG** Richtlinie des Rates zur Angleichung der Rechtsvorschriften der Mitgliedstaaten über die elektromagnetische Verträglichkeit.  
*Council Directive on the approximation of the laws of the Member States relating to electromagnetic compatibility.*

**2006/95/EG** Richtlinie des Rates zur Angleichung der Rechtsvorschriften der Mitgliedstaaten betreffend elektrische Betriebsmittel zur Verwendung innerhalb bestimmter Spannungsgrenzen.  
*Council Directive on the approximation of the laws of the Member States related to electrical equipment designed for use within certain voltage limits.*

Die Konformität mit den Richtlinien wird nachgewiesen durch die Einhaltung folgender Normen:  
*Conformity to the Directives is assured through the application of the following standards:*

<b>Referenznummer:</b>	<b>Ausgabedatum:</b>	<b>Referenznummer:</b>	<b>Ausgabedatum:</b>
<i>Reference number:</i>	<i>Edition:</i>	<i>Reference number:</i>	<i>Edition:</i>
DIN EN 55022	2008-05	DIN EN 60335-1	2007-02
DIN EN 61000-4-2	2001-12	DIN EN 60335-1/A13	2009-05
DIN EN 61000-4-3	2008-06	DIN EN 60335-2-98	2009-04
DIN EN 61000-4-4	2005-07	DIN EN 62233	2008-11
DIN EN 61000-4-5	2007-06	DIN EN 62233 Ber.1	2009-04
DIN EN 61000-4-6	2008-04		

Die Anforderungen des Geräte- und Produktsicherheitsgesetzes (GPSG) §4 Abs. 1 bis 3 werden eingehalten. Eine vom Lieferzustand abweichende Veränderung des Gerätes führt zum Verlust der Konformität. *The requirements of the German Appliance and Product Safety Law (GPSG) paragraph 4 clause 1 to 3 are met. Product modifications after delivery may result in a loss of conformity.*

Henstedt-Ulzburg, den / the 16.11.2009

HygroMatik GmbH

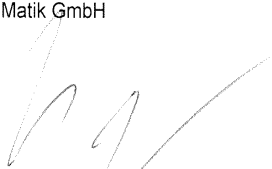
  
Maike Nielsen  
General Manager

  
Dirc Menssing  
Technical Manager / Quality Manager

Diese Erklärung bescheinigt die Übereinstimmung mit den genannten Richtlinien, ist jedoch keine Zusicherung von Eigenschaften. Die Sicherheitshinweise der mitgelieferten Produktdokumentation sind zu beachten.  
*This declaration certifies the conformity to the specified directives but contains no assurance of properties. The safety documentation accompanying the product shall be considered in detail.*

## 11. Spare Parts

*	HL6	HL9	HL12	HL18	HL24	HL27	HL30	HL36	HL45	Article No.	Description
											<b>Cabinet</b>
	1	1	1	1	1	1				B-2129001	Cabinet HL 6-27
							1	1	1	B-2129003	Cabinet HL 30-45
	1	1	1	1	1	1	1	1	1	E-2124008	Key for safety lock
											<b>Steam Generation</b>
	1									B-2205315	Cylinder compl. incl. 1 heater element 4,5 kW, 1 thermal sensor and terminal
		1								B-2205317	Cylinder compl. incl. 1 heater element 6,75 kW, 1 thermal sensor and terminal
			1							B-2205319	Cylinder compl. incl. 2 heater element 4,5 kW, 1 thermal sensor and terminal
				1						B-2205321	Cylinder compl. incl. 2 heater element 6,75 kW, 1 thermal sensor and terminal
					1					B-2205323	Cylinder compl. incl. 4 heater element 4,5 kW, 1 thermal sensor and terminal
						1				B-2205331	Cylinder compl. with 4 heater elements 6,75kW, 1 thermal sensor and terminal
							1			B-2205325	Cylinder compl. incl. 5 heater element 4,5 kW, 1 thermal sensor and terminal
								1		B-2205327	Cylinder compl. incl. 4 heater element 6,75 kW, 1 thermal sensor and terminal
									1	B-2205329	Cylinder compl. incl. 5 heater element 6,75 kW, 1 thermal sensor and terminal
	1									B-2206341	Steam cylinder top for HL 06 complete
		1								B-2206343	Steam cylinder top for HL 09 complete
			1							B-2206345	Steam cylinder top for HL 12 complete
				1						B-2206347	Steam cylinder top for HL 18 complete
					1					B-2206349	Steam cylinder top for HL 24 complete
						1				B-2206351	Steam cylinder top for HL 27 complete
							1			B-2206353	Steam cylinder top for HL 30 complete
								1		B-2206355	Steam cylinder top for HL 36 complete
									1	B-2206357	Steam cylinder top for HL 45 complete
5	1	1								E-2205070	Cover for cylinder, small, for 1 heater element and 1 thermal sensor
5			1	1						E-2205072	Cover for cylinder, small, for 2 heater element and 1 thermal sensor
5						1				E-2205064	Cover for cylinder, small for 3 heater element and 1 thermal sensor
5					1					E-2205074	Cover for cylinder, small, for 4 heater element and 1 thermal sensor
5								1		E-2205066	Cover for cylinder, big, for 4 heater element and 1 thermal sensor
5							1		1	E-2205068	Cover for cylinder, big, for 5 heater element and 1 thermal sensor
9	1	1	1	1	1	1				E-2205078	Cylinder- lower part, small
9							1	1	1	E-2205076	Cylinder- lower part, big
	1	1	1	1	1	1				E-2205104	Belt for HL cylinder fixation, short
							1	1	1	E-2205106	Belt for HL cylinder fixation, long
15	1	1	1	1	1	1				E-2205086	O-ring, cylinder lower part - cylinder cover, small
15							1	1	1	E-2205084	O-ring, cylinder lower part - cylinder cover, big
8	1		2		4		5			B-2205083	Heater element, 400V/4,5 kW incl. gasket, plates
8		1		2		3		4	5	B-2205085	Heater element, 400V/6,75 kW incl. gasket, plates
16	1	1	2	2	4	3	5	4	5	E-2205062	Pressureplate for heater element attachment
	1	1	1	1		1				E-2525504	Terminal 6 pole, 16mm <sup>2</sup>
					1		1	1	1	E-2525500	Terminal 9 pole, 16mm <sup>2</sup>
29	1	1	1	1	1	1	1	1	1	E-2205126	Thermal sensor (cylinder cover) 105°C since 01/2013
29	1	1	1	1	1	1	1	1	1	B-2205031	Thermal sensor (heater element) incl. sealing since 01/2013
	4	4	8	8	8	8	8	8	8	E-2205012	Clamp for thermal sensor since 01/2013
29	1	1	1	1	1	1	1	1	1	B-2205029	Thermal sensor incl. Sealing until 12/2012
	1	1	1	1	1	1	1	1	1	E-2205029	Protection cap for thermal sensor
	4	4	8	8	8	8	8	8	8	E-2205028	Clamp for thermal sensor until 12/2012
2	1	1	1	1	1	1	1	1	1	B-2205025	Steam hose adapter DN40
3	1	1	1	1	1	1	1	1	1	B-2304067	Nozzle for steam hose adapter
24	1	1	1	1	1	1	1	1	1	E-2209002	Clip for steam hose adapter DN40
4	1	1	1	1	1	1	1	1	1	E-2204022	O-ring for steam hose adapter DN40
1	2	2	2	2	2	2	2	2	2	E-2205088	Star knob screw, fixation steam hose adapter HL

*	HL6	HL9	HL12	HL18	HL24	HL27	HL30	HL36	HL45	Article No.	Description
											<b>Steam generation with electrical supply 440V</b>
	1									B-2205407	Cylinder compl. incl. 1 heater element 4,5 kW, 1 thermal sensor and terminal
		1								B-2205409	Cylinder compl. incl. 1 heater element 6,75 kW, 1 thermal sensor and terminal
			1							B-2205411	Cylinder compl. incl. 2 heater element 4,5 kW, 1 thermal sensor and terminal
				1						B-2205413	Cylinder compl. incl. 2 heater element 6,75 kW, 1 thermal sensor and terminal
					1					B-2205415	Cylinder compl. incl. 4 heater element 4,5 kW, 1 thermal sensor and terminal
						1				B-2205423	Cylinder compl. with 3 heater elements 6,75kW, 1 thermal sensor and terminal
							1			B-2205425	Cylinder compl. incl. 5 heater element 4,5 kW, 1 thermal sensor and terminal
								1		B-2205427	Cylinder compl. incl. 4 heater element 6,75 kW, 1 thermal sensor and terminal
									1	B-2205429	Cylinder compl. incl. 5 heater element 6,75 kW, 1 thermal sensor and terminal
											<b>Steam generation with electrical supply 480V</b>
	1									B-2205335	Cylinder compl. incl. 1 heater element 4,5 kW, 1 thermal sensor and terminal
		1								B-2205337	Cylinder compl. incl. 1 heater element 6,75 kW, 1 thermal sensor and terminal
			1							B-2205339	Cylinder compl. incl. 2 heater element 4,5 kW, 1 thermal sensor and terminal
				1						B-2205341	Cylinder compl. incl. 2 heater element 6,75 kW, 1 thermal sensor and terminal
					1					B-2205353	Cylinder compl. incl. 4 heater element 4,5 kW, 1 thermal sensor and terminal
						1				B-2205361	Cylinder compl. with 3 heater elements 6,75kW, 1 thermal sensor and terminal
							1			B-2205355	Cylinder compl. incl. 5 heater element 4,5 kW, 1 thermal sensor and terminal
								1		B-2205357	Cylinder compl. incl. 4 heater element 6,75 kW, 1 thermal sensor and terminal
									1	B-2205359	Cylinder compl. incl. 5 heater element 6,75 kW, 1 thermal sensor and terminal
											<b>Steam generation with electrical supply 690V</b>
	1									B-2205483	Cylinder compl. incl. 1 heater element 4,5 kW, 1 thermal sensor and terminal
		1								B-2205485	Cylinder compl. incl. 1 heater element 6,75 kW, 1 thermal sensor and terminal
			1							B-2205431	Cylinder compl. incl. 2 heater element 4,5 kW, 1 thermal sensor and terminal
				1						B-2205433	Cylinder compl. incl. 2 heater element 6,75 kW, 1 thermal sensor and terminal
					1					B-2205435	Cylinder compl. incl. 4 heater element 4,5 kW, 1 thermal sensor and terminal
						1				B-2205437	Cylinder compl. with 3 heater elements 6,75kW, 1 thermal sensor and terminal
							1			B-2205439	Cylinder compl. incl. 5 heater element 4,5 kW, 1 thermal sensor and terminal
								1		B-2205441	Cylinder compl. incl. 4 heater element 6,75 kW, 1 thermal sensor and terminal
									1	B-2205487	Cylinder compl. incl. 5 heater element 6,75 kW, 1 thermal sensor and terminal
											<b>Water Feed HL</b>
14	1	1	1	1	1	1				B-2304055	Double solenoid valve, 0,2-10 bar, 200-240VAC, 2,5 l/min
14							1	1	1	B-2304057	Double solenoid valve, 0,2-10 bar, 200-240VAC, 3,5 l/min
	1	1	1	1	1	1	1	1	1	E-2304024	Fine filter in solenoid valve
	1	1	1	1	1	1	1	1	1	E-2304103	Captive coupling ring for solenoid valve 3/4"
32	1	1	1	1	1	1	1	1	1	E-2304107	Gasket for inlet screwed fitting, solenoid
	1	1	1	1	1	1	1	1	1	E-8501034	Hose collar for inlet screwed fitting, 3/4", solenoid
56	1	1	1	1	1	1	1	2	2	B-2304031	Hose for water connection, 3/4" cap nuts on both sides, seal included
	1	1	1	1	1	1	1	1	1	E-2304036	Rubber seal solenoid valve - cabinet

*	HL6	HL9	HL12	HL18	HL24	HL27	HL30	HL36	HL45	Article No.	Description
	1	1	1	1	1	1	1	1	1	B-2304040	Mounting set for solenoid valve
31	1,6	1,6	0,8	0,8	0,8	0,8	0,8	0,8	0,8	E-2604002	Hose, solenoid valve - cabinet
33	1,7	1,7	0,3	0,3	0,3	0,3	0,3	0,3	0,3	E-2604002	Hose, solenoid valve - SuperFlush
	1	1	1	1	1	1	1	1	1	E-2604044	Buckling protection for hose, solenoid valve - cylinder base
6	1	1	1	1	1	1	1	1	1	B-2504129	Control cylinder for water level, compl. with flow switch
6	1	1	1	1	1	1	1	1	1	E-2504174	Control cylinder for water level, without flow switch
27	1	1	1	1	1	1	1	1	1	B-2504145	Flow switch with sealings and screws
28	1	1	1	1	1	1	1	1	1	E-2304038	Rubber seal for water level control
30	0,48	0,48	0,48	0,48	0,48	0,48	0,54	0,54	0,54	E-2604002	Hose, cylinder base - control cylinder
36	0,3	0,3	0,3	0,3	0,3	0,3	0,3	0,3	0,3	E-2604002	Hose, control cylinder - steam hose adapter
38	0,75	0,75	0,75	1	1	1	1	1	1	E-2604002	Hose for manual drain
	1	1	1	1	1	1	1	1	1	E-2604021	T-piece, condensate manifold, type TS12, DN12
20	1	1	1	1	1	1	1	1	1	E-2204035	Condensate plug DN12
	1	1	1	1	1	1	1	1	1	E-2604064	Handhold stopper for condensate hose
58	2	2	2	2	2	2	2	2	2	E-2604094	Double check valves
34	11	11	11	11	11	11	11	11	11	E-2304015	Hose clamp DN12
39	2	2	2	2	2	2	2	2	2	E-8501064	Hose clamp Dn 14.2
											<b>Water Drain HL</b>
11	1	1	1	1	1	1	1	1	1	E-2205050	Cylinder base
12	1	1	1	1	1	1	1	1	1	E-2205052	Strainer basket
13	1	1	1	1	1	1	1	1	1	E-2205048	O-ring, cylinder base - steam cylinder
10	1	1	1	1	1	1	1	1	1	B-2404027	Drain pump 230V/50-60Hz without mounting set
19	1	1	1	1	1	1	1	1	1	B-2424014	Mounting set for drain pump
	1	1	1	1	1	1	1	1	1	E-2404008	Drain pump housing
18	1	1	1	1	1	1	1	1	1	E-3220005	O-ring, cylinder base - drain pump
21	1	1	1	1	1	1	1	1	1	E-2425002	Adapter, pump - drain hose, straight model, connections DN25/13
	1	1	1	1	1	1	1	1	1	E-2404024	O-ring for drain pump
35	1	1	1	1	1	1	1	1	1	E-2425004	Elbow with vent pipe
23	0,8	0,8	0,8	0,8	0,8	0,8	0,9	0,9	0,9	E-2604002	Hose, drain pump - elbow
22	0,8	0,8	0,8	0,8	0,8	0,8	0,9	0,9	0,9	E-2604004	Drain hose, elbow - outlet
											<b>Control</b>
	1	1	1							B-2507041	Main contactor 20A, DILM7, Coil voltage .230VAC
				1		1				B-2507061	Main contactor 35A, DILM17, Coil voltage 230VAC
					1		1			B-2507071	Main contactor 50A, DILM40, Coil voltage 230VAC
								1	1	B-2507081	Main contactor 65A, DILM50, Coil voltage. 230VAC
	1	1								B-2602001	Solid state relay 25 A, 1ph., heat sink (150 x 50) mm,
			1	1						B-2602003	Solid state relay 50 A, 2ph., heat sink (150 x 50) mm (not used for slave devices)
					1					B-2602105	Solid state relay 50 A, 2ph., heat sink (150 x 80) mm (not used for slave devices)
						2	2	2	2	B-2602009	Solid state relay 75 A, 1ph., heat sink (150 x 80) mm (not used for slave devices)
	1	1								E-2205110	Solid state relay 25 A, 1ph.
			1	1	1					E-2205112	Solid state relay 50 A, 2ph.
							2	2	2	E-2205114	Solid state relay 75 A, 1ph.
											<b>Steam generation with electrical supply 380-480V</b>
	1	1	1	1						B-2507041	Main contactor 20A, DILM17, Coil voltage 230VAC
						1				B-2507061	Main contactor 35A, DILM17, Coil voltage 230VAC
					1		1			B-2507071	Main contactor 50A, DILM40, Coil voltage. 230VAC
								1	1	B-2507081	Main contactor 65A, DILM50, Coil voltage. 230VAC
	1	1								B-2602001	Solid state relay 25 A, 1ph., heat sink (150 x 50) mm,
			1	1						B-2602003	Solid state relay 50 A, 2ph., heat sink (150 x 50) mm (not used for slave devices)
					1					B-2602105	Solid state relay 50 A, 2ph., heat sink (150 x 80) mm (not used for slave devices)
						2	2	2	2	B-2602009	Solid state relay 75 A, 1ph., heat sink (150 x 80) mm (not used for slave devices)

*	HL6	HL9	HL12	HL18	HL24	HL27	HL30	HL36	HL45	Article No.	Description
											<b>Steam generation with electrical supply 600-690V</b>
	1	1	1	1	1					B-2507041	Main contactor 20A, DILM17, Coil voltage 230VAC
						1	1	1	1	B-2507061	Main contactor 35A, DILM17, Coil voltage 230VAC
	1	1	1	1	1	1	1	1	1	E-2205130	Solid state relay 75A/690V, without heat sink, single phase
	1	1				2	2	2	2	E-2205100	Protection cap against contact without cutout
			1	1	1					E-2205102	Protection cap against contact with cutout
	1	1	1	1		2	2	2		E-2205116	heat sink (150 x 50) mm
					1					E-2205118	heat sink (150 x 80) mm
	1	1	1	1	1	2	2	2	2	E-2205108	Thermal circuit breaker with manual reset, 100°C ± 5K (not used for slave devices)
	1	1	1	1		1				E-2525506	Terminal 6 pole, 6mm <sup>2</sup> (mounted)
					1		1	1	1	E-2525502	Terminal 9pole, 6mm <sup>2</sup> (mounted)
											<b>Basic</b>
	1	1	1	1	1	1	1	1	1	B-2526203	Electronic pcb Basis for HL
							1	1	1	B-2526203	Elektronik pcb Basis for slave units
	(1)	(1)	(1)	(1)	(1)	(1)	(1)	(1)	(1)	B-2526213	Electronic pcb Basis for HL steambath
	1	1	1	1	1	1	1	1	1	B-2120901	Mounting plate with foil for Basic (without display)
	1	1	1	1	1	1	1	1	1	B-2120909	Mounting plate with foil for Basic (without display)
	1	1	1	1	1	1	1	1	1	E-2525410	Foil for mounting plate, type Basic
	(1)	(1)	(1)	(1)	(1)	(1)	(1)	(1)	(1)	E-2525418	Foil for mounting plate, type Basic DS
	(1)	(1)	(1)	(1)	(1)	(1)	(1)	(1)	(1)	B-2526303	Relais pcb for Basis pcb
											<b>Comfort</b>
	1	1	1	1	1	1	1	1	1	B-2526203	Electronic pcb Basis for HL
							1	1	1	B-2526203	Elektronik pcb Basis for slave units
	(1)	(1)	(1)	(1)	(1)	(1)	(1)	(1)	(1)	B-2526213	Electronic pcb Basis for HL steambath
	(1)	(1)	(1)	(1)	(1)	(1)	(1)	(1)	(1)	B-2526401	Comfort display incl. mounting plate with foil
	(1)	(1)	(1)	(1)	(1)	(1)	(1)	(1)	(1)	B-2526445	Comfort display incl. mounting plate with foil DS
	(1)	(1)	(1)	(1)	(1)	(1)	(1)	(1)	(1)	B-2120903	mounting plate with foil for Comfort unit
	(1)	(1)	(1)	(1)	(1)	(1)	(1)	(1)	(1)	B-2120911	mounting plate with foil for Comfort unit DS
	(1)	(1)	(1)	(1)	(1)	(1)	(1)	(1)	(1)	E-2525412	Foil for mounting plate type Comfort
	(1)	(1)	(1)	(1)	(1)	(1)	(1)	(1)	(1)	E-2525420	Foil for mounting plate type Comfort DS
											<b>Comfort Plus</b>
	1	1	1	1	1	1	1	1	1	B-2526203	Electronic pcb Basis for HL
							1	1	1	B-2526203	Elektronik pcb Basis for slave units
	(1)	(1)	(1)	(1)	(1)	(1)	(1)	(1)	(1)	B-2526213	Electronic pcb Basis for HL steambath
	(1)	(1)	(1)	(1)	(1)	(1)	(1)	(1)	(1)	B-2526403	Comfort Plus display incl. mounting plate with foil
	(1)	(1)	(1)	(1)	(1)	(1)	(1)	(1)	(1)	B-2526447	Comfort Plus display incl. mounting plate with foil DS
	(1)	(1)	(1)	(1)	(1)	(1)	(1)	(1)	(1)	B-2120905	Mounting plate with foil for Comfort Plus
	(1)	(1)	(1)	(1)	(1)		(1)	(1)	(1)	B-2120907	Mounting plate with foil for Comfort Plus with master pcb, display and foil (available soon)
	(1)	(1)	(1)	(1)	(1)	(1)	(1)	(1)	(1)	B-2120913	Mounting plate with foil for Comfort Plus DS
	(1)	(1)	(1)	(1)	(1)	(1)	(1)	(1)	(1)	E-2525414	Foil for mounting plate Comfort Plus
	(1)	(1)	(1)	(1)	(1)	(1)	(1)	(1)	(1)	E-2525422	Foil for mounting plate Comfort Plus DS
											<b>Accessories</b>
										B-3216091	O-ringset for HL 6 - 27
										B-3216093	O-ringset for HL 30 - 45
										E-2604034	Reducing piece DN 40/DN 25 for steam hose
										E-2604012	Steam hose DN 25, per m
										E-2604013	Steam hose DN 40, per m
										E-2604002	Condensate hose DN 12, per m
										E-2604004	hose, vent - outlet (14,2 x 3 mm)
										E-2404004	Steam hose clamp DN 25
										E-2604016	Steam hose clamp DN 40
										E-2304015	Condensate hose clamp DN 12
										E-2604042	Steam manifold T-piece DN 25, stainless steel
										E-2604023	Steam manifold T-piece DN 40, stainless steel
										E-2604000	Steam manifold Y-piece DN 40, stainless steel
										E-2604021	Condensate connector T-piece DN 12
										B-2604025	Steam solenoid valve 0-0,4 bar, compl. for steam hose DN 25
										B-2604040	Steam solenoid valve 0-0,4 bar, compl. for steam hose DN 40
										E-2604029	Hose nozzle DN 25 - R 3/4"
										E-2504031	Driller (17-21mm)

If you order any spare parts, specify type and serial number

\* see exploded view



## 12. Fax Form - Order for spare parts

**Airtrend Ltd.-Gobrid. Ltd.**  
Kumanovska 14, 11000 Beograd  
Tel. +381 11 383 68 86, 308 57 40  
Faks +381 11 344 41 13  
E-mail: gobrid@eunet.rs

### Fax Form

Please copy, fill in and fax to

Fax.No. **+381 11 344 41 13**

# Order of spare parts

unit type \* \_\_\_\_\_ serial no.\* \_\_\_\_\_

commission: \_\_\_\_\_ order no.: \_\_\_\_\_

quantity	article	article no.

date of delivery \_\_\_\_\_ forwarder \_\_\_\_\_ shipment by \_\_\_\_\_

delivery address (if different  
from invoice address)

\_\_\_\_\_  
\_\_\_\_\_  
\_\_\_\_\_  
\_\_\_\_\_

company stamp (delivery adress)

date/signature

\* Order can only be processed if unit type and unit serial no. are filled in.

### 13. Technical Specifications

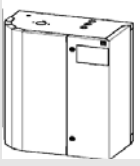
 <b>HeaterLine HL</b>									
Type	HL6	HL9	HL12	HL18	HL24	HL27	HL30	HL36	HL45
Steam Output [kg/h]	6	9	12	18	24	27	30	36	45
Electrical Supply*	400V/3/N 50-60Hz								
Power Rating [kW]	4,5	6,8	9,0	13,5	18,0	20,3	22,5	27,0	33,8
Power Consumption [A]***	11,3	16,9	19,5	29,3	39,0	29,3	39,0	58,5	58,5
Circuit Protection [A]	3x16	3x20	3x25	3x35	3x40	3x35	3x40	3x63	3x63
Control Type	Basic, Comfort and Comfort Plus								
Number of Steam Cylinder	1								
Number of Heater Elements	1	1	2	2	4	3	5	4	5
Steam Hose Connection	1x25mm**			1x40mm			2x40mm		
Condensate Hose Connection	1x12mm						2x12mm		
Net Weight [kg]	35	35	36	36	38	37	46	45	46
Operating Weight [kg]	48	48	49	49	51	50	72	71	72
Height [mm]	865						900		
Width [mm]	645						685		
Depth [mm]	335						395		
Water Supply HeaterLine	Fully Demineralized Water / Cleaned Condensate / Partially Softened Water / Tap Water (different qualities) 1 to 10 bar (100 x 10 <sup>3</sup> to 100 x 10 <sup>4</sup> Pa), 13mm Hose								
Fan Unit, Wall-Mounted	VG08	VG17	VG17	VG30	VG30	VG30	VG30	2x VG30	2x VG30
Airflow Capacity of Fan Unit [m <sup>3</sup> /h]	160	185	185	350	350	350	350	2x350	2x350

\* Other voltages upon request.

\*\* Reducing Piece DN40/DN25 included

\*\*\* Current load of phases is not uniform. See table below.

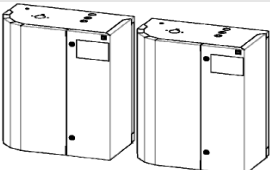
 <b>HeaterLine HL Double Units</b>				
Type	HL 60	HL 70	HL 80	HL 90
Steam Output [kg/h]	60	72	81	90
consist of:				
HL 30	2x			
HL 36		2x	1x	
HL 45			1x	2x

Max. current load [A] according to phase:

Phase	HL06	HL09	HL12	HL18	HL24	HL27	HL30	HL36	HL45
L1	11,3	16,9	11,3	16,9	22,5	29,3	29,8	33,8	44,7
L2	11,3	16,9	19,5	29,3	39,0	29,3	39,0	58,5	58,5
L3	0,2	0,2	11,3	16,9	22,5	29,3	29,8	33,8	44,7

## Technical Specifications



### HeaterLine HL for SPA HL6..-DS - HL45..-DS

Type	HL6	HL9	HL12	HL18	HL24	HL27	HL30	HL36	HL45
Steam Output [kg/h]	6	9	12	18	24	27	30	36	45
Electrical Supply*	400V/3/N 50-60Hz								
Power Rating [kW]	4,5	6,8	9,0	13,5	18,0	20,3	22,5	27,0	33,8
Power Consumption [A]***	11,3	16,9	19,5	29,3	39,0	29,3	39,0	58,5	58,5
Circuit Protection [A]	3x16	3x20	3x25	3x35	3x40	3x35	3x40	3x63	3x63
Control Type	Basic-DS, Comfort-DS and Comfort Plus-DS								
Number of Steam Cylinder	1								
Number of Heater Elements	1	1	2	2	4	3	5	4	5
Steam Hose Connection	1x40			1x40mm				2x40mm	
Condensate Hose Connection	1x12mm							2x12mm	
Net Weight [kg]	35	35	36	36	38	37	46	45	46
Operating Weight [kg]	48	48	49	49	51	50	72	71	72
Height [mm]	865						900		
Width [mm]	645						685		
Depth [mm]	335						395		
Water Supply HeaterLine	Fully Demineralized Water / Cleaned Condensate / Partially Softened Water / Tap Water (different qualities)  1 to 10 bar (100 x 10 <sup>3</sup> to 100 x 10 <sup>4</sup> Pa), 13mm Hose								
* Other voltages upon request. *** Current load of phases is not uniform. See table below.									

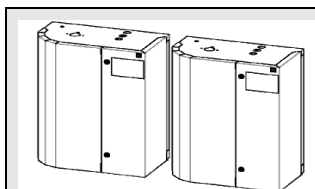

### HeaterLine HL Double Units

Type	HL 60	HL 70	HL 80	HL 90
Steam Output [kg/h]	60	72	81	90
consist of:				
HL 30	2x			
HL 36		2x	1x	
HL 45			1x	2x

Max. current load [A] according to phase:

Phase	HL06	HL09	HL12	HL18	HL24	HL27	HL30	HL36	HL45
L1	11,3	16,9	11,3	16,9	22,5	29,3	29,8	33,8	44,7
L2	11,3	16,9	19,5	29,3	39,0	29,3	39,0	58,5	58,5
L3	0,2	0,2	11,3	16,9	22,5	29,3	29,8	33,8	44,7

### 14. Exploded View

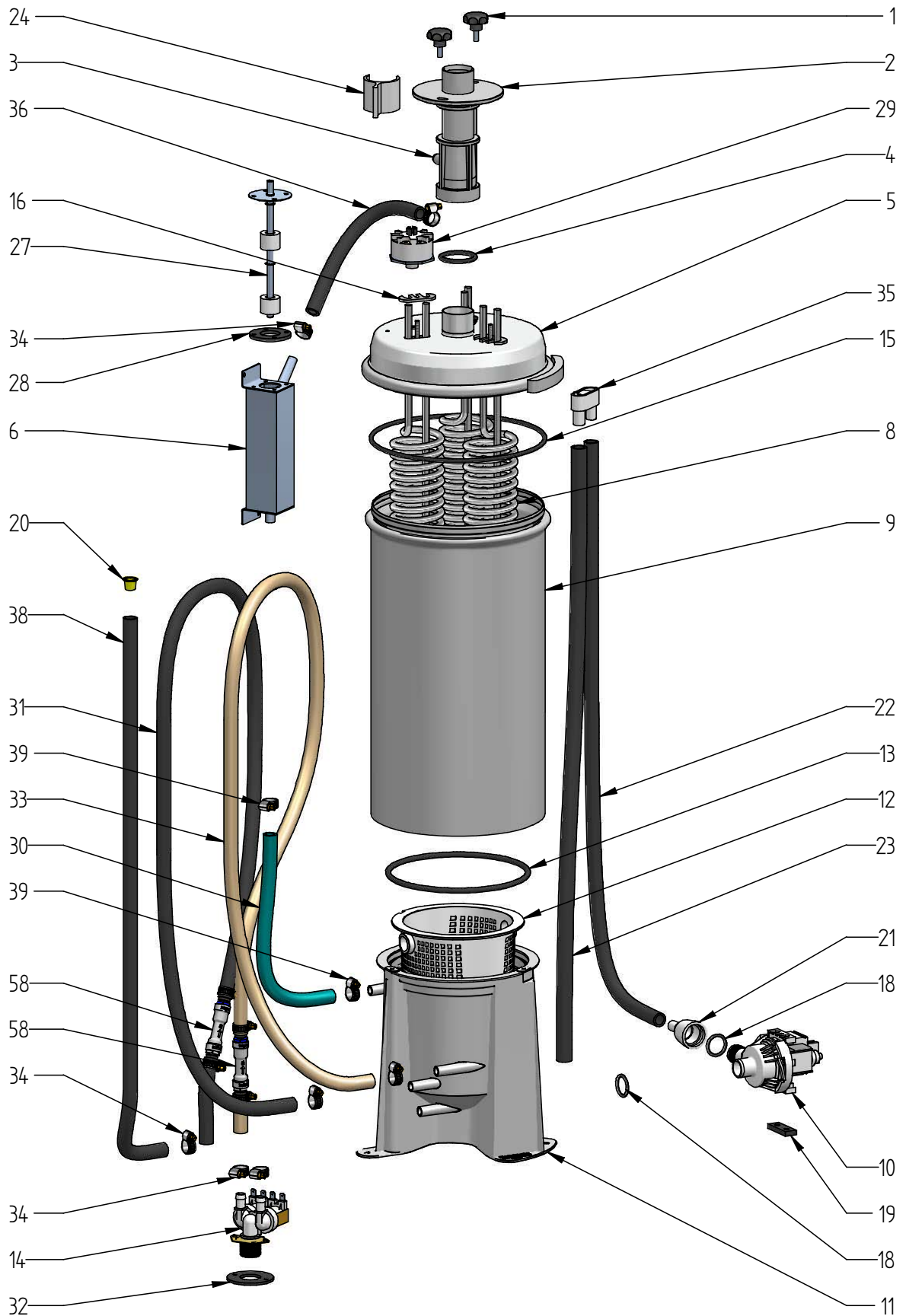

### 15. View of Cabinet

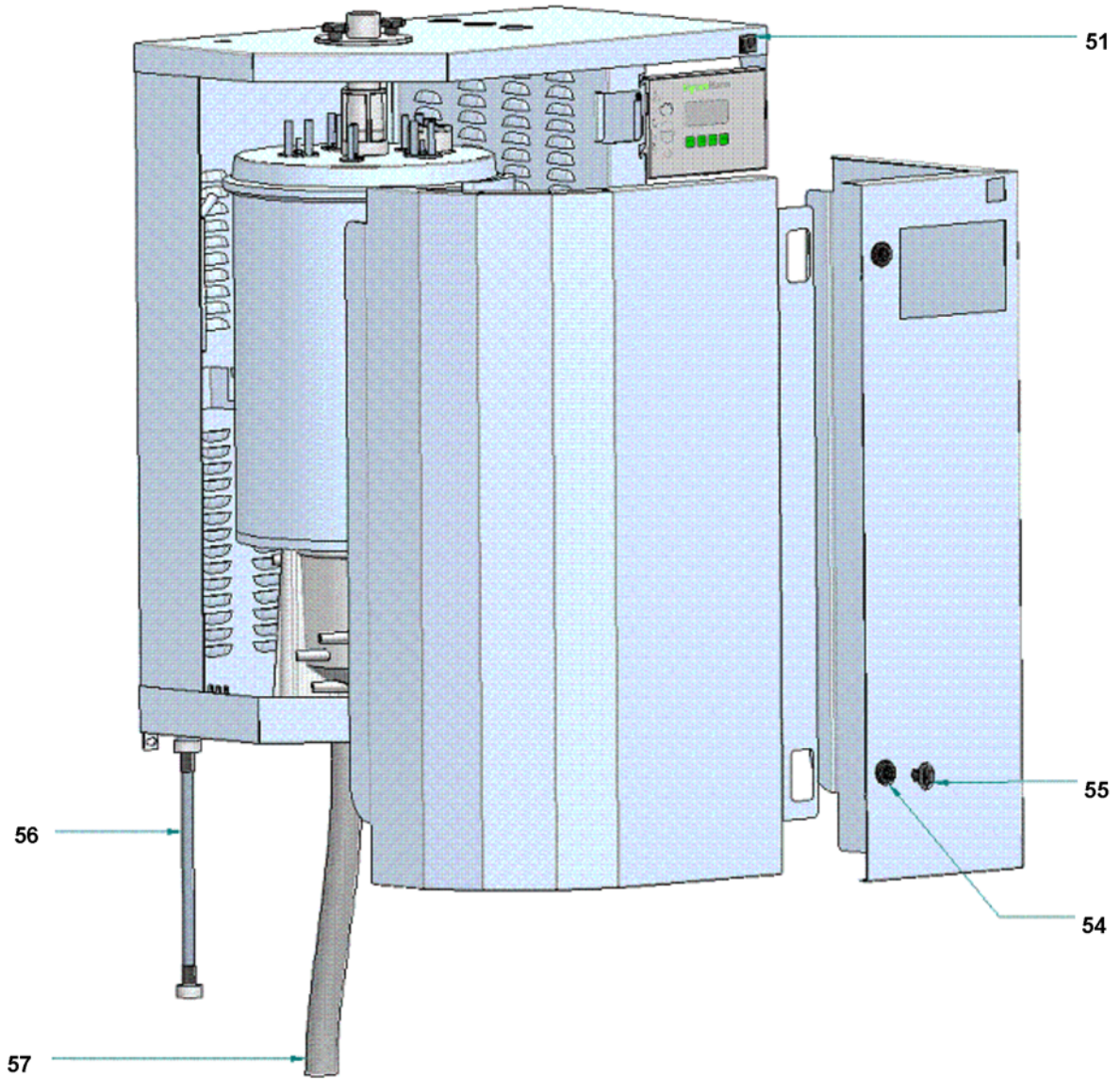



**HYGROMATIK<sup>®</sup>**

Predstavništvo u Beogradu  
**Airtrend Ltd.-Gobrid. Ltd.**  
Kumanovska 14, 11000 Beograd  
Tel. +381 11 383 68 86, 308 57 40  
Faks +381 11 344 41 13  
E-mail: gobrid@eunet.rs