

Chilled beam Flexicool® IQFD

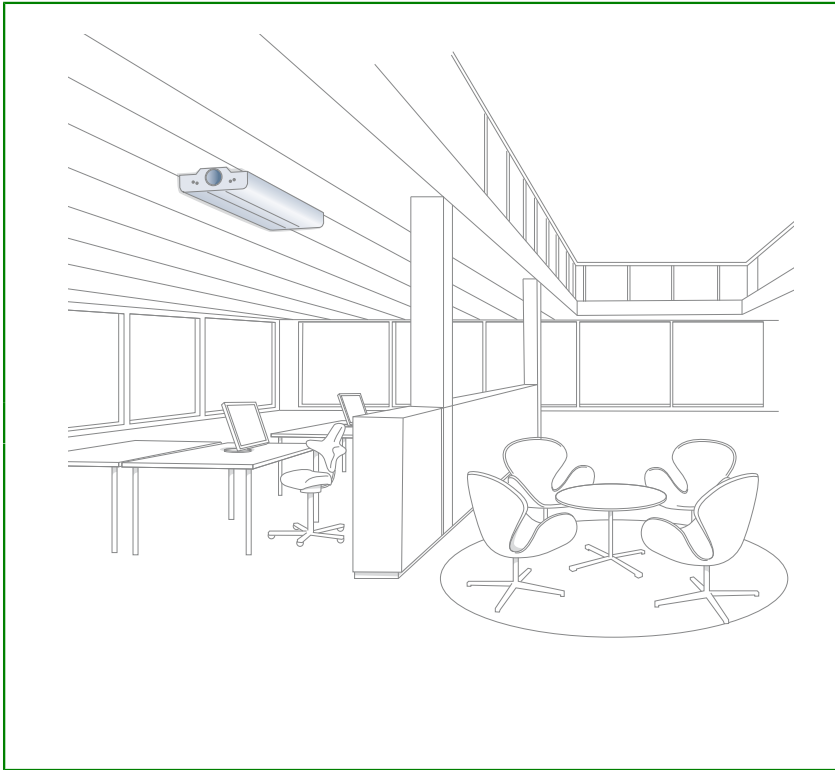

Functions

- FPC
- High air flow
- Controls
- Indirect and direct lighting
- Comfort control
- Heating



The chilled beam Flexicool® IQFD is an integrated system for ventilation, cooling and heating, fulfilling most needs for indoor climate. These supply air beams are designed to manage high cooling effects that, because of good mixing with room air, provide comfort and low air velocities in the occupied zone. IQFD is designed for exposed installation and is also available with fittings for indirect and direct illumination. The blow through the supply air slot is directed diagonally upwards, which increases the probability of adhesion to the ceiling and thereby draught-free room ventilation. The chilled beam is equipped with comfort control, for the adjustment of air flow, cooling effect and flow pattern (FPC).

Quick Selection

Cooling effect in W, supply air included

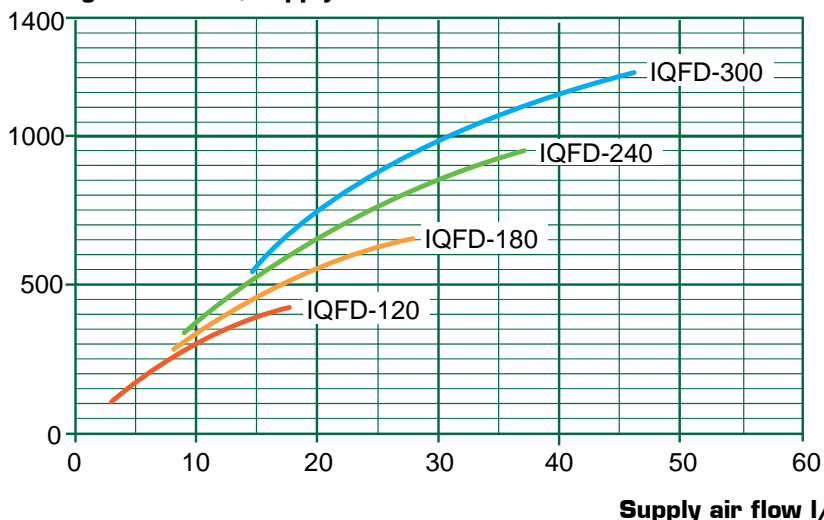

The diagram shows the approximate cooling effect, P_{tot} in W with water flow, $q_w = 0.05$ l/s, temperature difference between room air and supply air, $t = 8$ °C, pressure drop = 70 Pa on the air side and max sound pressure level $L_{A10} = 30$ dB(A).

Product Facts

- Chilled beam IQFD for exposed installation.
- Air flow through the supply air slots is directed diagonally upwards.
- Capacity and flow directions are easy adjustable.
- Side plate can be pushed aside to enable check-up and cleaning.
- Enclosures for connections are available as accessories.
- Attachments brackets for quick and easy mounting - lift up - snap on.

Product code example

Chilled beam IQFD for exposed installation manufactured by Fläkt Woods. With stepless regulation of air flow and upwards distribution pattern.

Chilled beam IQFD-240-1-1-02

Technical data for cooling and heating effect

Cooling effect for two-way chilled beam at static pressure drop 70 Pa on the air side

Beam length = 1,2 m (Coil length = 0,9 m)

Water flow, $q_w = 0.05$ l/s

Pressure drop water, $\Delta p_w = 1.8$ kPa

q_1 [l/s]	P_{tot} [W]			P_{coil} [W]			L_{A10} dB[A]
	Δt [°C]			Δt [°C]			
	6	8	10	6	8	10	
5	145	180	215	100	135	170	<20
10	260	315	370	165	220	275	<20
15	335	400	465	190	255	320	21

Beam length = 1,8 m (Coil length = 1,5 m)

Water flow, $q_w = 0.05$ l/s

Pressure drop water, $\Delta p_w = 2.7$ kPa

q_1 [l/s]	P_{tot} [W]			P_{coil} [W]			L_{A10} dB[A]
	Δt [°C]			Δt [°C]			
	6	8	10	6	8	10	
10	275	335	395	180	240	300	20
15	380	460	540	235	315	395	21
20	460	550	640	270	360	450	21
25	535	630	730	295	390	490	22

Beam length = 2,4 m (Coil length = 2,1 m)

Water flow, $q_w = 0.05$ l/s

Pressure drop water, $\Delta p_w = 3.3$ kPa

q_1 [l/s]	P_{tot} [W]			P_{coil} [W]			L_{A10} dB[A]
	Δt [°C]			Δt [°C]			
	6	8	10	6	8	10	
10	290	355	420	195	260	325	24
15	440	540	640	295	395	495	24
20	545	665	785	355	475	595	24
25	635	765	895	395	525	655	24
30	710	850	990	420	560	700	25
35	790	940	1090	455	605	755	26

Beam length = 3,0 m (Coil length = 2,7 m)

Water flow, $q_w = 0.05$ l/s

Pressure drop water, $\Delta p_w = 4.1$ kPa

q_1 [l/s]	P_{tot} [W]			P_{coil} [W]			L_{A10} dB[A]
	Δt [°C]			Δt [°C]			
	6	8	10	6	8	10	
15	455	555	660	310	410	515	27
20	600	735	870	410	545	680	28
25	720	880	1040	480	640	800	28
30	810	985	1160	520	695	870	28
35	875	1055	1235	540	720	900	30
40	960	1145	1335	565	750	940	29
45	1020	1215	1410	590	785	980	28

Conditions for cooling effect tables

Total cooling effect of beam P_{tot} = cooling effect of coil P_{coil} + cooling effect of supply air P_{air} .

The assumed pressure drop on the air side is 70 Pa.

The cooling effect of supply air is based on an undertemperature of 8 °C for the supply air, when compared to the room temperature.

The effects for other water flows can be found in the Fläkt Woods product selection program.

Note! The tables here are based on tests done according to the Nordtest method. The purpose of this method is to be able to compare different chilled beams on the same terms. The method requires a non-existing temperature difference between the air entering the beam coil and the air at 1.1 m above floor surface. To achieve this, the walls in the test room are cooled.

In actual conditions, the temperature difference is normally 1 - 2 °C. This is why the temperature difference Δt should be increased by 1 - 2 °C to avoid overdimensioning of the beam. This means that the table value concerned can be increased by 10 - 20 %.

With top connection the sound generation increases by 3 - 4 dB(A).

The chilled beam can be supplied with a special construction for higher air flows than listed in these tables.

Heating effect for two-way chilled beam IQFD at static pressure drop 70 Pa on the air side

Heating effects can be found in separate catalogue section, heating.

Definitions

q_1	Supply air flow, l/s
P_{tot}	Total cooling capacity, W
P_{coil}	Cooling capacity of the coil, W
$P_{coil\ heat}$	Heating effect of the coil, W
L_{A10}	Sound pressure level in a room with 10 m ² room absorption, dB(A)
Δt	Difference between room air temperature and average water temperature, K
Δp_w	Pressure drop water, kPa
Δt_w	Water temperature in the coil, K. Calculated with the formula: $\Delta t_w = P_{coil} / 208$

Technical data for flow patterns, sound data, function

Technical data for flow patterns other than two-way air distribution

Beams with two-way air distribution utilize the coil in full, which is not the case in one-way distribution or middle positions. This effect factor can be found in the table below.

For a particular beam and supply air flow, the obtained effect factor is multiplied by the value given in the effect tables on the previous page.

Type of distribution	Beam length, m	Max. supply air flow, l/s	Effect factor
One-way	1,2	10	0,8
	1,8	15	0,8
	2,4	25	0,8
	3,0	30	0,8
70% - 30%	1,2	10	0,9
	1,8	20	0,9
	2,4	30	0,9
	3,0	40	0,9

Example

Requirements:

Beam of length = 2.4 m with one-way air distribution, air flow = 20 l/s, pressure drop air = 70 Pa, difference between room air temperature and average water temperature = 8° C and water flow = 0.05 l/s.

Result:

The table on the previous page gives coil effect $P_{\text{coil}} = 475$ W.

Effect factor = 0,8

Coil effect for one-way air distribution = $0,8 \times 475 = 380$ W

Sound power level

IQFD	Correction K_{Oct} , dB							
	Octave band, middle frequency (Hz)							
	63	125	250	500	1000	2000	4000	8000
-120	3	-6	-5	-2	-1	-1	-7	-14
-180	3	-6	-5	-2	-1	-1	-7	-14
-240	3	-6	-5	-2	-1	-1	-7	-14
-300	3	-6	-5	-2	-1	-1	-7	-14
Tol +/-	6	3	2	2	2	2	2	3

The sound power levels for every octave band are obtained by adding together the sound pressure level L_{A10} , dB(A), and the corrections K_{Oct} given in the table above, according to the following formula:

$$L_W = L_{A10} + K_{\text{Oct}}$$

The correction K_{Oct} is the average in the area of application of the chilled beam IQFD.

Sound attenuation

IQFD	Sound attenuation in supply air duct of the beam ΔL , dB							
	Octave band, middle frequency (Hz)							
	63	125	250	500	1000	2000	4000	8000
-120	26	16	9	8	9	11	12	13
-180	26	16	9	8	9	11	12	13
-240	26	16	9	8	9	11	12	13
-300	26	16	9	8	9	11	12	13
Tol +/-	6	3	2	2	2	2	2	3

Construction and function

The chilled beam IQFD is designed for exposed installation.

The blow through the supply air slot is directed diagonally upwards, which increases the probability of adhesion to the ceiling and thereby draught-free room ventilation.

The air flow can be adjusted by means of the patented adjusting rails, comfort control, or by changing the length of the holes in the supply air duct. This can easily be done with normal adjustments.

The adjustable hole lengths allow different air distribution (two-way, one-way and middle positions).

The simple adjustment of air distribution and capacity makes it possible to adapt to changing conditions in the future.

Before delivery, the hole lengths of standard beams are preset at the longest possible position to provide a starting position for later adjustment

The side plate can be pushed aside to enable adjustment of air flow and cleaning.

The purging nipple is a choice in the product code.

Material and surface finish

The casing is mainly made of galvanized steel sheet. The frontplate is powder painted in white. The standard colour RAL 9010, which corresponds to NCS 0502-Y, gloss level 30. Coil made of copper pipe with connection $\text{Ø}_{\text{out}} = 15$ mm, and aluminium fins. Maximum working pressure 1.6 MPa.

Lighting, dimensions and weights, enclosure

IQFD with direct- and/or indirect lighting

Direct lighting

Dimensions

Beam-length, m	Length of lighting fixture, mm	Number of lighting fixtures	Effect, W
1.8	1200	1	28/54
2.4	1500	1	35/49
3	1200	2	28/54

The connection cord can be delivered with plug, EnstoNet-, Wieland- or Mate-n-lock plug.

Indirect lighting

Dimensions

Beam-length, m	Length of lighting fixture, mm	Number of fixtures	Effect, W
1.8	1200	2*	28/54
2.4	1800	2*	2x21/2x39**
3	2400	2*	2x28/2x54**

* one fixture in every wing

** two fluorescent lamps in every fixture.

The connection cord can be delivered with plug or EnstoNet-plug.

Dimension and weights

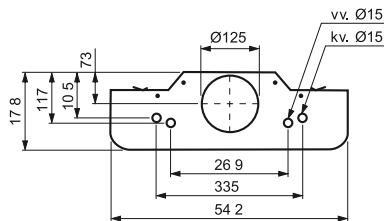
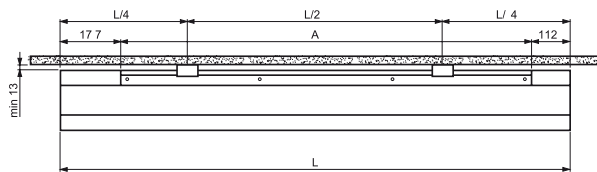

Size	L [mm]	A [mm]
IQFD-120	1202	913
IQFD-180	1800	1511
IQFD-240	2405	2116
IQFD-300	2996	2707

Weight/m chilled beam	kg/m
Dry weight	15
Water filled, cooling	15.5
Water filled, cooling and heating	15.7

Enclosure IQAZ-21

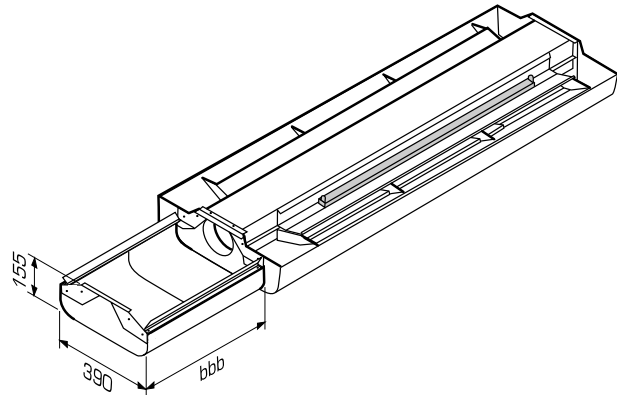

IQAZ-21	Length, mm
-050	300-500
-090	500-900
-170	900-1700

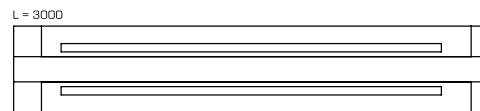
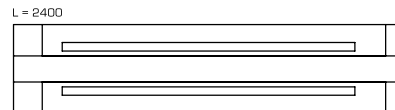
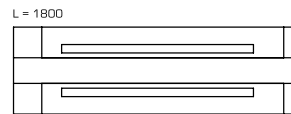
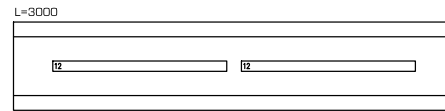
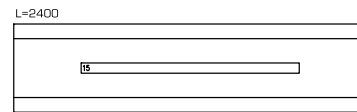
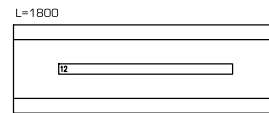

Product code, accessories

Description

Chilled beam IQFD for exposed installation manufactured by Fläkt Woods. With stepless regulation of air flow and upwards distribution pattern.

Product code

Main code

**Supply air beam
for exposed installation,
standard**

IQFD-aaa-b-c-dd

Nominal length, cm (aaa)
120, 180, 240, 300

Connection alternative (b)

1 = air and water horizontally through gable

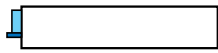

2 = air and water horizontally through opposite gables

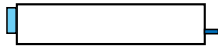

3 = air and water vertically through top panel

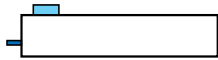

Coil construction (c)

1 = Cooling

2 = Cooling with purging nipple on the right side

3 = Cooling and heating

5 = Cooling and heating with purging nipple on the right side

Comfort control (dd)¹⁾

01 = With CC, 1 hole row

02 = With CC, 1 hole row, FPC

03 = With CC, 2 hole rows

04 = With CC, 2 hole rows, FPC

05 = Without CC, 1 hole row

06 = Without CC, 1 hole row, FPC

07 = Without CC, 2 hole rows

08 = Without CC, 2 hole rows, FPC

¹⁾ 1 hole row = normal air flow

2 hole rows = high air flow

Special constructions

Describe the deviations from the standard model clearly and replace the product code letter standing for the construction part in question with an X.

Accessories

**Fastening bracket,
unpainted**

QFAZ-20

Set containing 2 pcs.
1 pc. QFAZ-20 per beam

IMAGE QFAZ-20_List MISSING

**Fastening bracket,
unpainted**

QFAZ-18-5-1

Set containing 2 pcs.
1 pc. QFAZ-18-5-1 per beam



Suspension brackets

QFAZ-11-5

Set containing 2 pcs.
1 pc. QFAZ-11-5 per beam

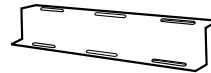

Suspension rods M8

QFAZ-12

Set with 2 pcs. Length 500 mm.
2 sets QFAZ-12 per beam



**Enclosure, without end
walls**

IQAZ-21-bbb

Between beam and wall,
attachments are included

Length (bbb)

050 = 30-50 cm

090 = 50-90 cm

170 = 90-170 cm

IMAGE IQAZ-21_List MISSING

**Control equipment, FPC, High Air Flow, Lighting,
Comfort control and Heating. Descriptions included in a
separate section of this catalogue.**